



www.teamcracing.net

# TR10

*Instruction manual*

**1/10 SCALE RADIO CONTROL TOURING CAR**

### **Dimensions**

Length	.....	420mm
Width	.....	190mm
Height	.....	105mm

## Notiz

Danke das Sie sich für das Produkt TR10 Onroad Touring Car von Team C entschieden haben. Bitte nehmen Sie sich Zeit und lesen Sie sich die Anleitung genau durch.

Wir verbessern kontinuierlich unsere Produkte, so können die tatsächlichen Teile von den Abbildungen abweichen. Bitte schauen Sie zuerst auf unsere Homepage ob es neue Versionen von den Anleitungen oder neue Tips gibt, bevor Sie das zusammenbauen beginnen.

This manual is written in german language only. If you need a manual in your language please visit our website or contact your distributor!

Diese Anleitung wurde in deutscher Sprache verfasst. Sollten sie eine Anleitung in ihrer Sprache benötigen, besuchen sie unsere website oder kontaktieren sie ihren Vertriebsagenten.

Questo manuale è stato scritto in tedesco. Se avete bisogno del manuale nella tua lingua, si prega di visitare il nostro sito web o contattate il proprio distributore.

Este manual está escrito en aleman. Si necesita el manual en su idioma, por favor visite nuestro sitio web o contacte con su distribuidor.

Ce manuel est écrit en langue allemand. Si vous avez besoin d'un manuel dans votre langue s'il vous plaît visitez notre site web ou contactez votre distributeur!

Deze handleiding is geschreven in het duits taal beschikbaar. Als u een handleiding in uw eigen taal kunt u terecht op onze website of neem contact op met uw distributeur!

## Generelle Information

### **DAS IST KEIN SPIELZUG!**

Nicht geeignet für Kinder unter 14 Jahren ohne Aufsicht eines Erwachsenen.

Dies ist ein Hochleistungs Fahrzeug und darf aus Sicherheitsgründen nicht auf öffentlichen Straßen, in überfüllten Gebieten und umweltfreundlichen Bereichen oder in der Nähe von Kindern und Tieren gefahren werden.

Dieses Modell enthält rotierende Teile und Teile die während des Betriebes heiß werden können. Um Schäden und Verletzungen zu vermeiden ist Vorsicht beim Betrieb des Fahrzeuges geboten.

Dieses Produkt erfordert möglicherweise Reperatur- und Wartungsarbeiten.

Dieses Produkt ist durch Gewährleistung auf Material Defekte abgedeckt. Unfallschäden oder Wartungsschäden werden nicht von der Gewährleistung abgedeckt.

Batterien müssen in einwandfreiem Zustand sein und sollten immer voll geladen sein.

Nitro Modelle dürfen nur außerhalb von Gebäuden gefahren werden. Inhalieren von Auspuffabgasen kann zu gesundheitlichen Schäden führen.

Bewahren Sie Chemikalien unzugänglich von Kindern auf.

Stellen Sie sicher das Ihr Fahrzeug und das nötige Equipment in einwandfreiem Zustand ist, damit ein sicherer Betriebszustand gewährleistet ist und Sie Spaß am fahren haben.

## Notice

Thank you for purchasing this TR10 Onroad Touring Car by Team C.  
Please take some time to read through to get familiar with the shown steps.

We continually improve our products, due to that, actual parts may be different to the illustrations.  
Please check our website for the latest versions manuals and tips before you start to build this model.

This manual is written in English language only. If you need a manual in your language please visit our website or contact your distributor!

Diese Anleitung wurde in englischer Sprache verfasst. Sollten sie eine Anleitung in ihrer Sprache benötigen, besuchen sie unsere website oder kontaktieren sie ihren Vertriebsagenten.

Questo manuale è stato scritto in inglese. Se avete bisogno del manuale nella tua lingua, si prega di visitare il nostro sito web o contattate il proprio distributore.

Este manual está escrito en Inglés. Si necesita el manual en su idioma, por favor visite nuestro sitio web o contacte con su distribuidor.

Ce manuel est écrit en langue anglaise. Si vous avez besoin d'un manuel dans votre langue s'il vous plaît visitez notre site web ou contactez votre distributeur!

Deze handleiding is geschreven in het Engels taal beschikbaar. Als u een handleiding in uw eigen taal kunt u terecht op onze website of neem contact op met uw distributeur!

## General Information

**THIS IS NOT A TOY!**

Not suitable for children under 14 years of age without adult supervision.

This is a high performance vehicle, for safety reason don't run on public streets, in crowded areas, environmentally areas or near children or animals.

This model contains rotating parts and parts which become hot during operation. Care must be taken to avoid damage or injuries.

This product may require some assembly and routine maintenance.

This product is covered by warranty based on material defectives. Crash damage or maintenance failures are not covered under warranty.

Batteries should be used in good condition only, and need to be fully charged.

Nitro models should be driven outside of buildings only. Inhaling exhaust gases could cause health damage.

Keep chemicals stored out of the range of small children.

Make sure your model and equipment is in perfect condition before you use it, to ensure safety and fun while driving.

## Allgemeine Grundlagen

### Ein bisschen Theorie ist notwendig!

Sie wollen nun endlich Ihr RC Car losknallen lassen - was müssen sie dabei beachten?

#### **Wichtig: Batterien oder Akkus der Fernsteuerung sollten immer voll geladen sein!**

Batterien oder Akkus nie ganz leer fahren. Warum? Es kann Ihnen dann passieren das die Fernsteuerung ausgeht, das Sendesignal zum Empfänger abreißt und Ihr RC Car sich selbst ständig macht - das kann teuer werden!

Fahrvorbereitung:

Achten Sie bitte immer darauf das Sie **zuerst die Fernsteuerung einschalten und dann erst den Fahrtenregler**. Bocken Sie das Fahrzeug auf, damit sich die Räder frei drehen können. Schalten Sie jetzt den Sender ein danach schalten Sie den Fahrtenregler ein. Überprüfen Sie jetzt die Fahrtauglichkeit der Lenkung links/rechts und Gas/Bremse.

Machen Sie jetzt zuerst ein paar langsame Runden, damit Sie sich mit dem Fahrzeug vertraut machen bevor Sie Vollgas geben. Denken Sie immer daran - **ein RC Car ist wirklich kein Spielzeug** - Sie können sich selbst und andere damit schwer verletzen.

Wenn Sie zuerst das Fahrzeug einschalten kann es passieren das der Empfänger ein anderes Signal empfängt und das Fahrzeug von alleine davon fährt - **und das kann sehr gefährlich und auch teuer werden!**

#### **Bitte beachten Sie immer - Don't drink and drive!**

Thema Wasser:

Es wird sicherlich vorkommen, dass Sie ab und zu bei Geländefahrten durch eine Pfütze fahren. Bedenken Sie hier, dass der Empfänger, der Motor und Akku gegen Feuchtigkeit sehr empfindlich sind. Fahren Sie nicht unnötig in große Pfützen und lassen Sie Ihr Fahrzeug bei starkem Regen zu Hause. Ein Wasserspritzer am falschen Ort und Sie können Ihre Ausfahrt beenden und sich schonmal überlegen bei welchem Modellbauhändler Sie Ersatzteile nachbestellen.

Thema Wiese:

Fahrten auf Wiesen mit langen Gräsern und Stopeln haben leider auch Ihre Tücken. Das Gras kann sich in den Antriebswellen verwickeln. Dies führt zu einer unnötigen und zusätzlichen Belastung des Motors und er kann überhitzen.

Thema Sprünge:

Das gehört klar dazu und genau deshalb kauft man sich einen Hyde oder Stoke usw. Ist für diese Fahrzeuge auch überhaupt kein Problem, wenn man nicht allzu leichtsinnig ans Werk geht. Damit Sie nach einem Sprung wieder auf den Rädern landen müssen Sie mit der Fernsteuerung arbeiten. Wenn Sie merken das die Nase vom Fahrzeug immer mehr in Richtung Boden schaut dann geben Sie Gas damit sich die Nase wieder anhebt. Wenn Sie Gas weg nehmen wird sich die Nase in Richtung Boden senken.

#### **Dies machen Sie aber bitte erst wenn Sie sich mit dem Fahrzeug vertraut gemacht haben und auf eigene Verantwortung!**

## General informations

### A bit of theory is necessary!

You want your RC car is finally going to pop - what they need to consider?

#### **Important: Batteries of the radio control should always be fully charged!**

Batteries never run completely discharged. Why? The radio control can assume, the transmission signal to the receiver breaks off and the car is driving without control.

Driving preparation:

#### **Please always make sure that you turn on the radio control first and then the esc.**

Jack up the car so the wheels can rotate freely. Now switch on the radio control and then the esc. Now check the roadworthiness of the steering left / right and throttle / brake.

Now take a few slow laps, so that you become familiar with the car before you open full throttle. Notice - **the RC car isn't a toy** - you can hurt yourself and other people.

When you first turn on the vehicle it may happen that the receiver is receiving another signal and the vehicle is driving off alone - **and this can be very dangerous and also expensive!**

#### **Pay attention - Don't drink and drive!**

Theme water:

It will certainly happen that you driving through a puddle. Remember here that the receiver, motor and battery are very sensitive. Don't drive through big puddles and when it's heavy rain let your car at home.

Theme grass:

The grass can become tangled in the drive shafts. This leads to an unnecessary and additional load on the motor and it can overheat.

Theme jumps:

This is exactly why you buy a Hyde or a Stoke. This is not a problem for those cars when you do it right.

If you notice that the nose of the car looks more and more towards the ground you step on the throttle so that the nose lifts again. When you take gas off, the nose will go downwards.

#### **Please do this when you are familiar with the car and at your own risk!**

**1** Gear Differential  
Differential

**Bag-A**

**B101504/T02099**  
10x15x4 Ball Bearing  
10x15x4 Kugellager

.....1

**P210/T04032** 2x9.8 Pin  
2x9.8 Pin

.....1

**T01049** 5x15x0.3 Washer  
5x15x0.3 Beilagscheibe

.....1

**T01126** 5x1.9 O-Ring  
5x1.9 O-Ring

.....1

.....1

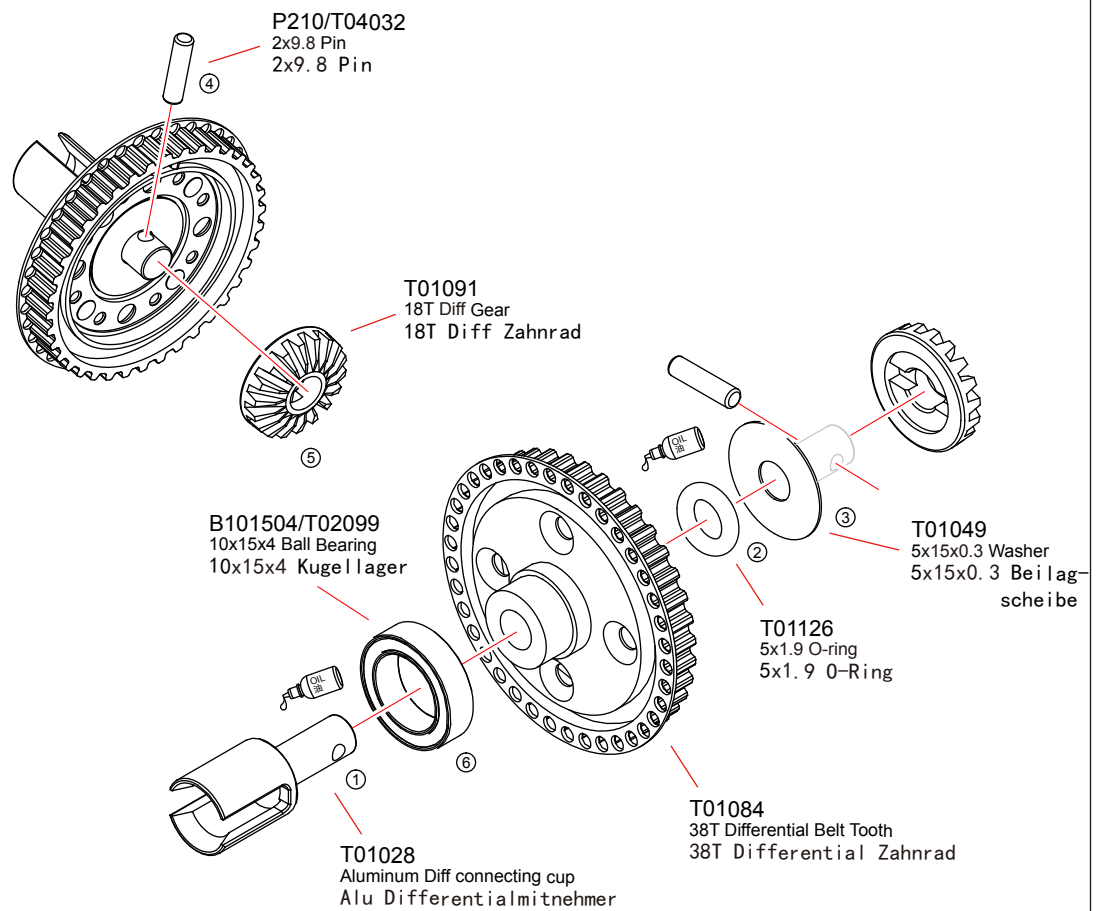

**2** Gear Differential  
Differential

**Bag-A**

**B101504/T02099**  
10x15x4 Ball Bearing  
10x15x4 Kugellager

.....1

**P210/T04032** 2x9.8 Pin  
2x9.8 Pin

.....1

**T01049** 5x15x0.3 Washer  
5x15x0.3 Beilagscheibe

.....1

**T01126** 5x1.9 O-Ring  
5x1.9 O-Ring

.....1

.....1

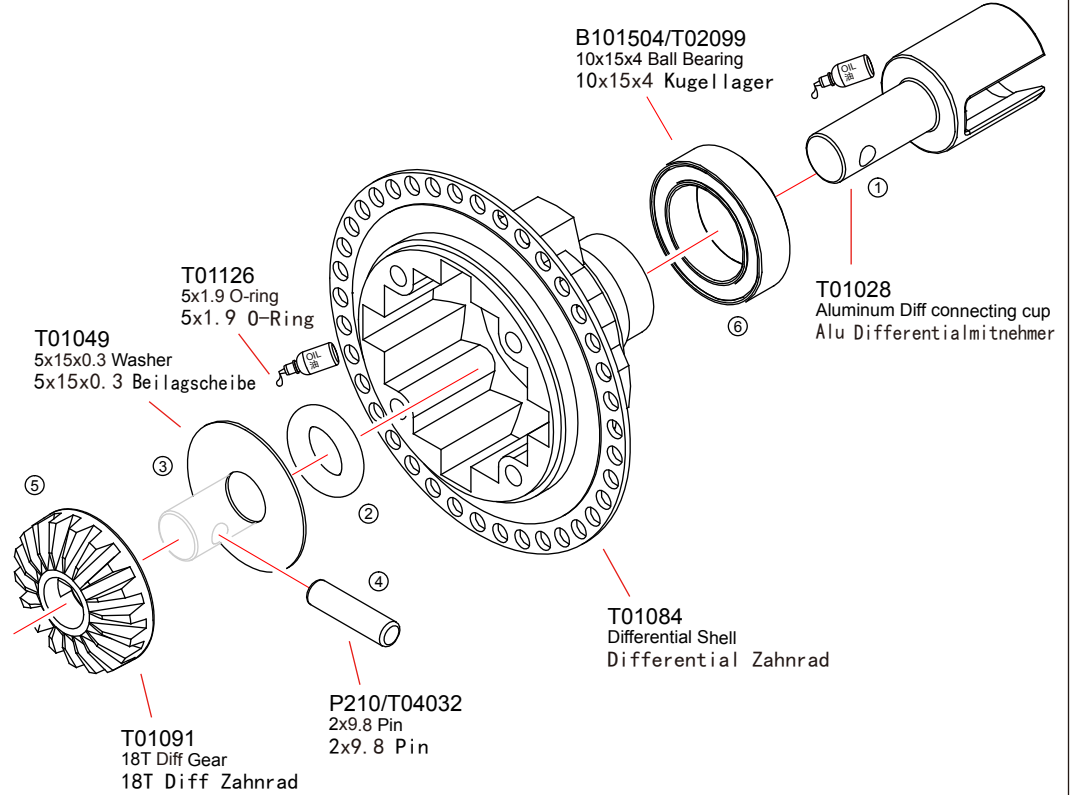

**3** Gear Differential  
Differential

**Bag-A**

T01049  
3.5x10x0.3 Washer  
3.5x10x0.3 Beilagscheibe



T01091  
Diff Gear Set  
Diff Gear Set

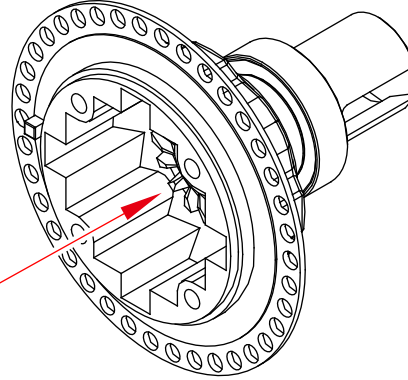
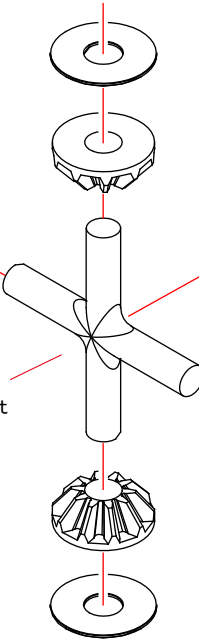
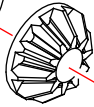

T01091  
10T Diff Gear  
10T Diff Zahnrad



T01049 3.5x10x0.3 Washer  
3.5x10x0.3 Beilagscheibe



.....4

**4** Gear Differential  
Differential

**Bag-A**

T01097  
24x0.7 O-ring  
24x0.7 O-Ring

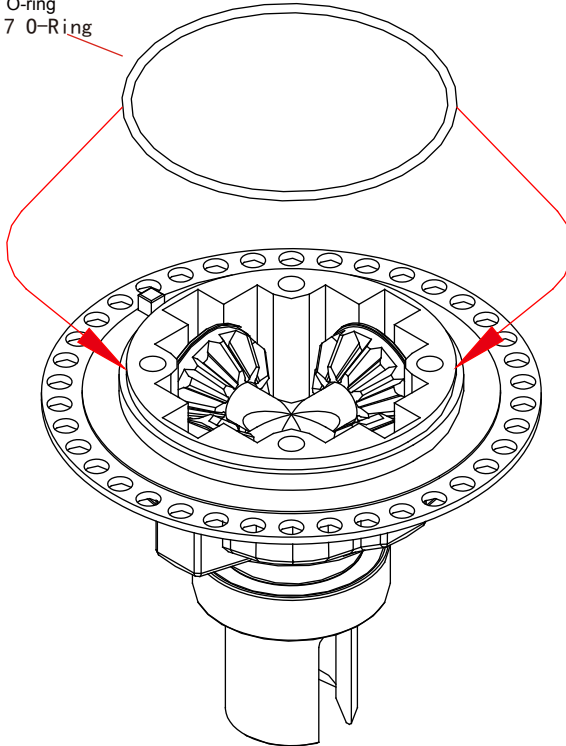

T01097 24x0.7 O-Ring  
24x0.7 O-Ring

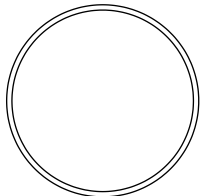

.....1

**5** Gear Differential  
Differential **Bag-A**

FS2508/T01117 M2.5x8 Screw  
M2.5x8 Schraube



FS2508/T01117  
M2.5x8 Screw  
M2.5x8 Schraube

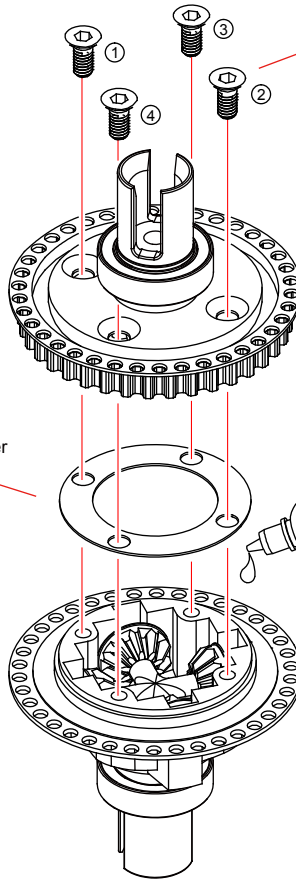

T01097  
Diff Leakproof Spacer  
Differential  
Dichtung

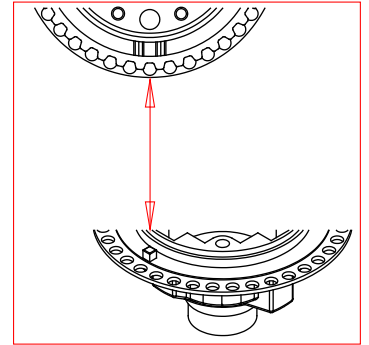
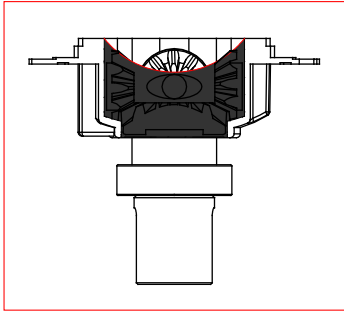

**6** Gear Differential  
Differential **Bag-A**

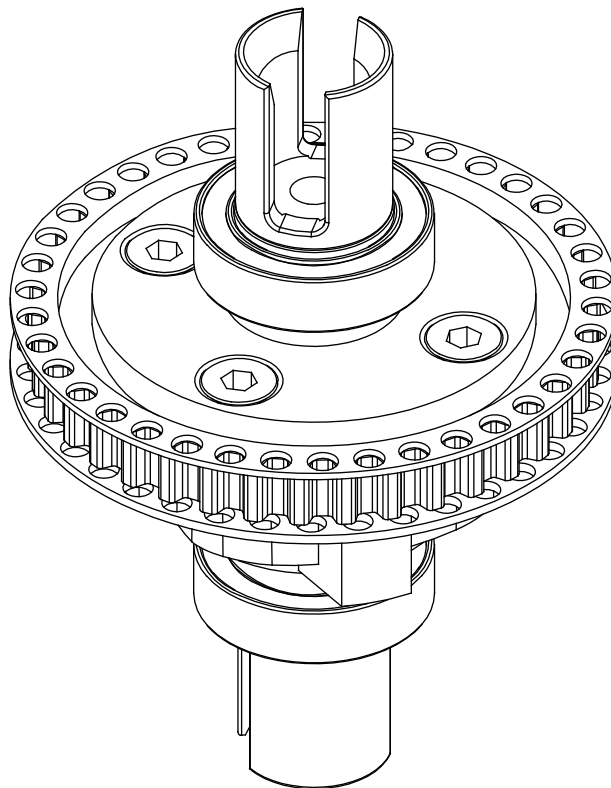



**7** Solid Axle  
Starrachse **Bag-A**

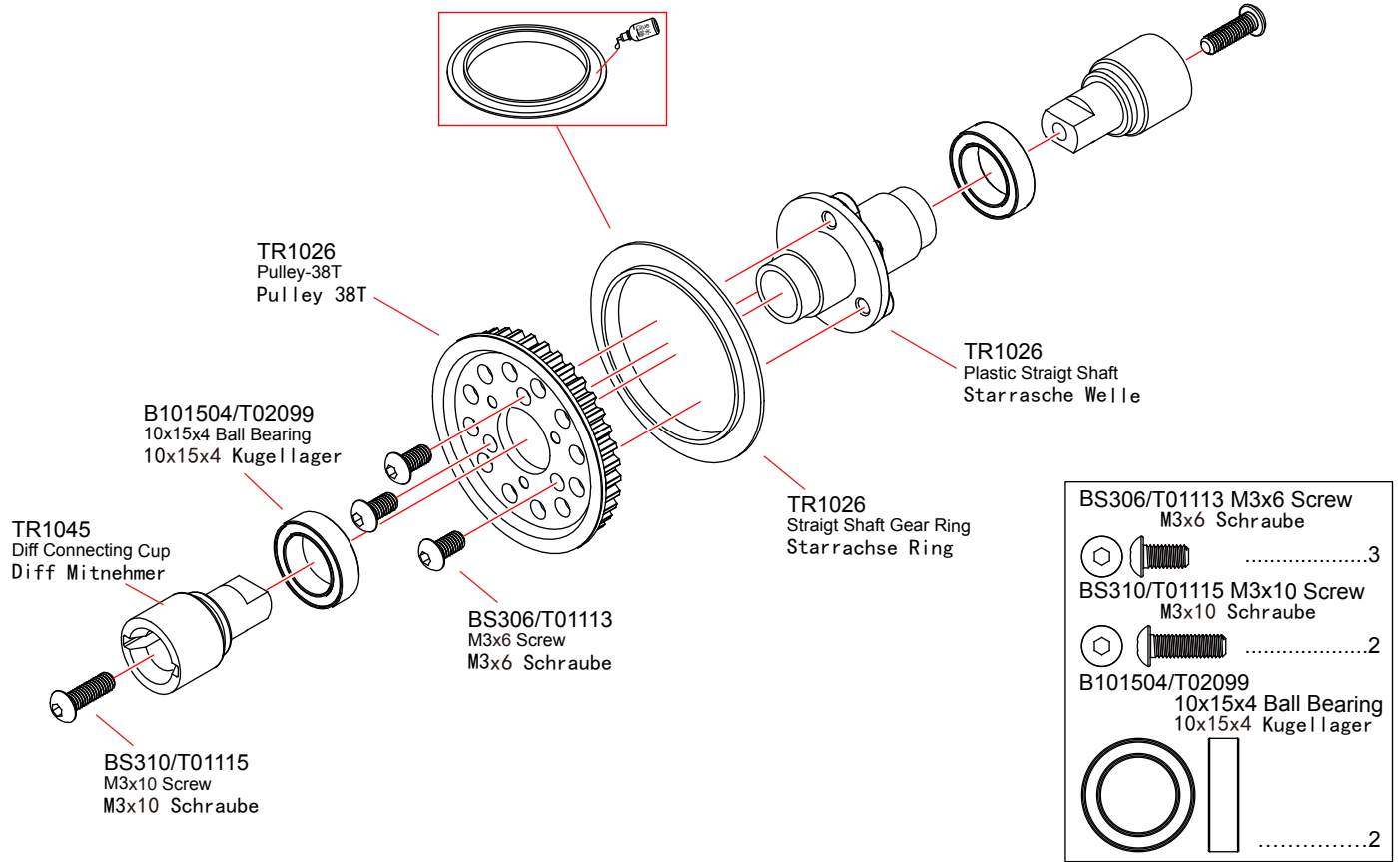

**8** Motor Mount/Side Panel  
Motorhalterung **Bag-B**

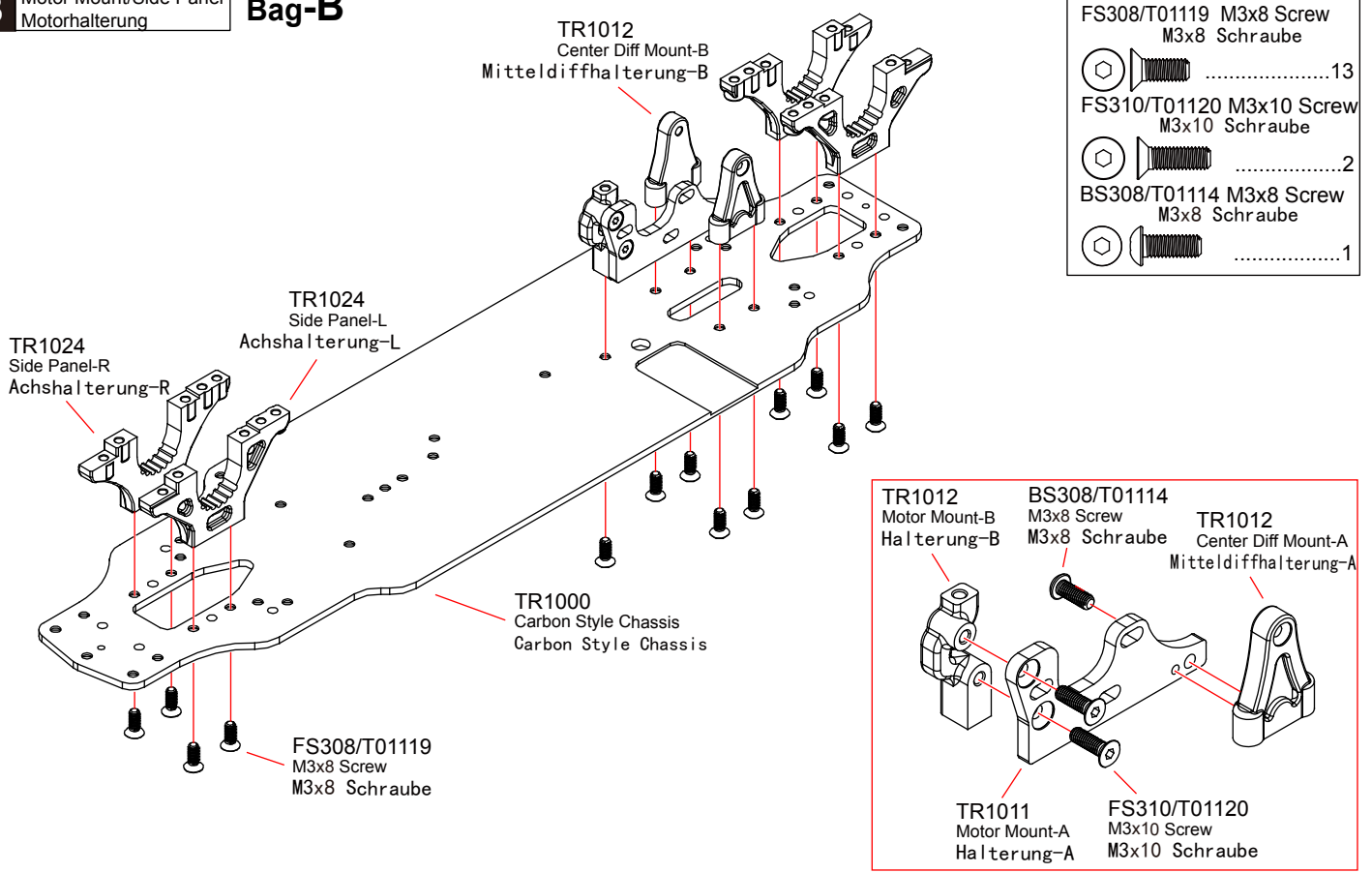

**9** Center Gear Adaptor  
Mitteldiff Adapter **Bag-B**

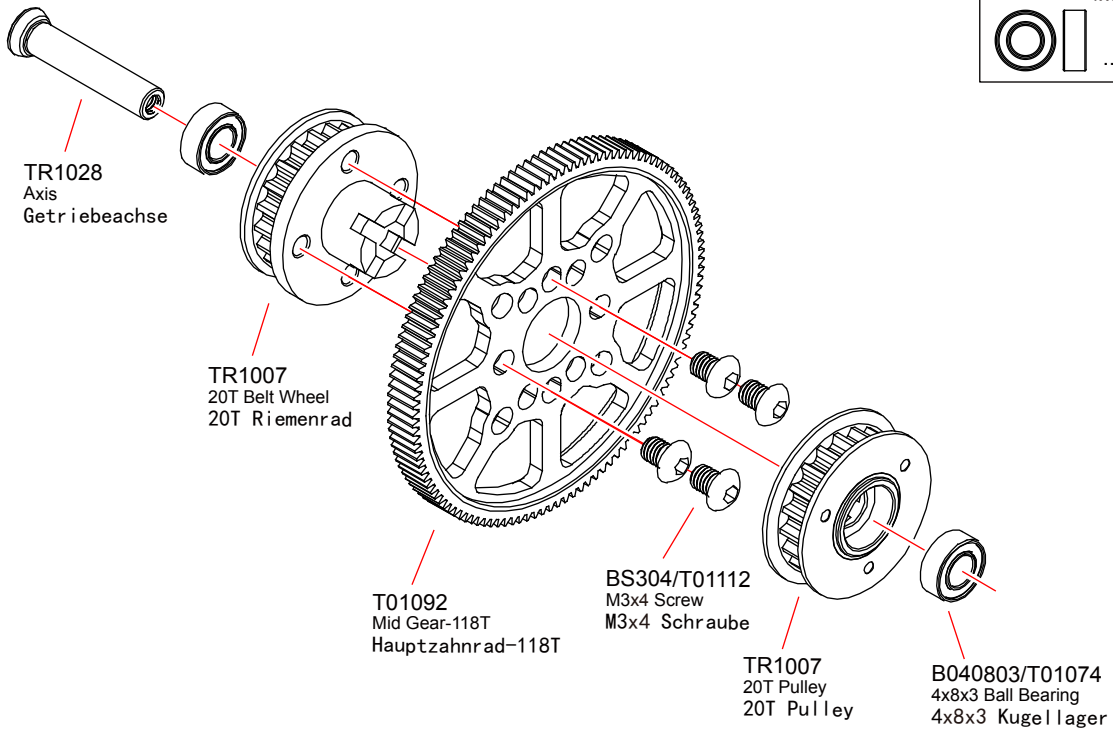

BS304/T01112 M3x4 Screw M3x4 螺絲	.....4
B040803/T01074 4x8x3 Ball Bearing 4x8x3 轴承	.....2

**10** Differential Assembly  
Diff Zusammenbau **Bag-B**

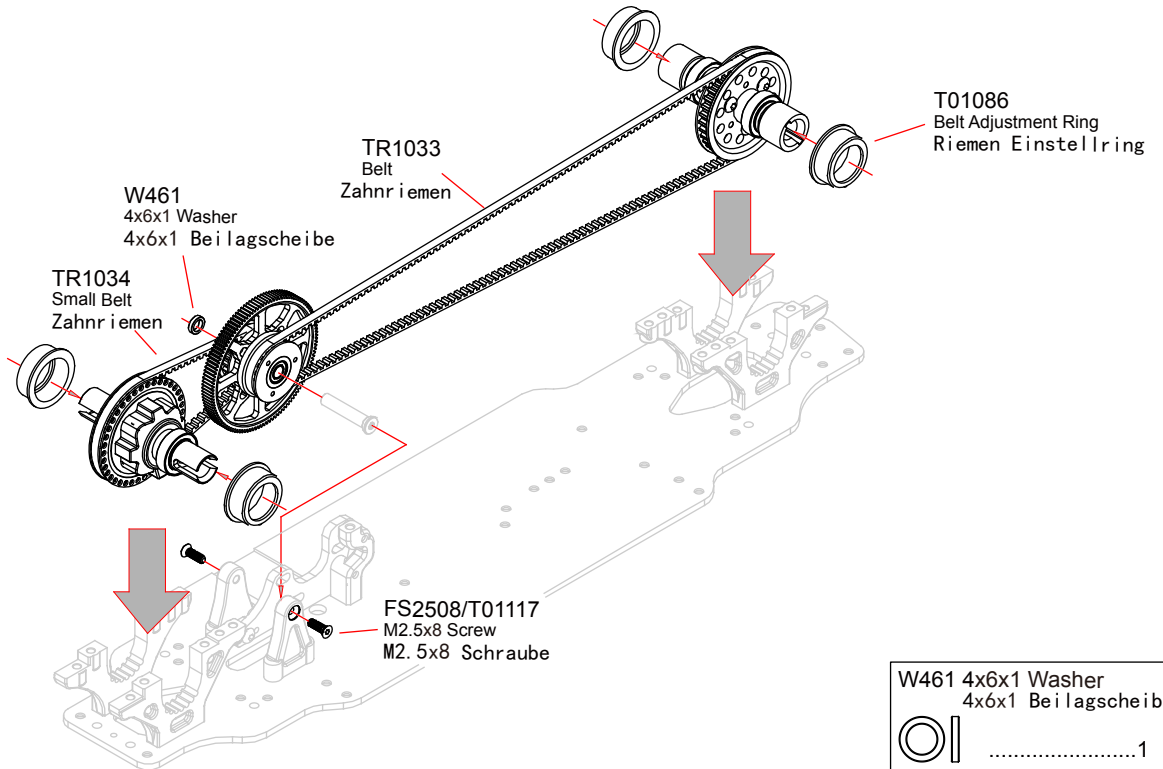

W461 4x6x1 Washer 4x6x1 Beilagscheibe	.....1
FS2508/T01117 M2.5x8 Screw M2.5x8 Schraube	.....2

**11** Differential Assembly  
Diff Zusammenbau

**Bag-B**

Front diff upper position provides more steering but provides less front traction. Recommended for medium-high grip tracks and technical tracks.  
Vorderes Diff, obere Position sorgt für mehr Lenkung bietet aber weniger Haftung an der Vorderachse. Empfohlen für medium high Grip Strecken und technisch anspruchsvollen Strecken.

Front diff low position provides more front traction but makes the car more push on power. Recommended for low traction track.  
Vorderes Diff, untere Position sorgt für mehr Haftung an der Vorderachse aber dadurch schiebt das Auto mehr. Empfohlen für geringe Traktions Strecken.

**TO LOOSEN FRONT BELT:** Rotate both front nylon hubs in arrow direction A  
Vorderen Riemen lösen: Drehen Sie beide vorderen Nylon Hubs in Pfeilrichtung A

**TO TIGHTEN FRONT BELT:** Rotate both front nylon hubs in arrow direction B  
Vorderen Riemen straffen: Drehen Sie beide vorderen Nylon Hubs in Pfeilrichtung B

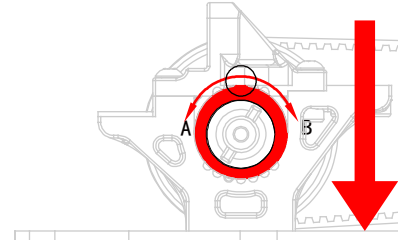
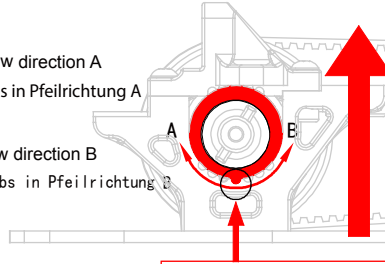

**INITIAL POSITION Ausgangslage**  
PLACE TAB IN THIS BOTTOM NOTCH Nase in die untere Kerbe einlegen

Rear diff upper position provides more on-power steering but makes the rear slightly more loose. Recommended for medium-high traction tracks.  
Hinteres Diff, obere Position bietet mehr On-Power Lenkung, macht aber das Heck rutschiger. Empfohlen für medium-high Strecken.

Rear diff lower position provides more rear traction, mainly on power traction and makes the car more stable in the chicanes, but makes the car push more on power. Recommended for low-medium traction.  
Hinteres Diff, untere Position bietet mehr Traktion an der Hinterachse, vor allem bei Power Traktion und macht in Schikanen das Auto stabiler. Empfohlen für low-medium Traktion.

**TO LOOSEN REAR BELT:** Rotate both rear nylon hubs in arrow direction A  
Hintere Riemen lösen: Drehen Sie beide hinteren Nylon Hubs in Pfeilrichtung A

**TO TIGHTEN REAR BELT:**  
Rotate both rear nylon hubs in arrow direction B  
Hintere Riemen straffen:  
Drehen Sie beide hinteren Nylon Hubs in Pfeilrichtung B

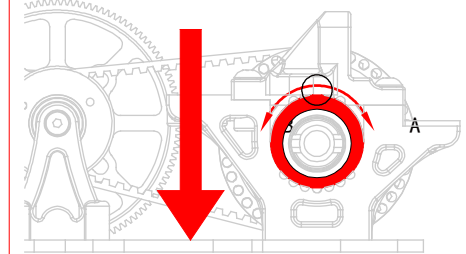
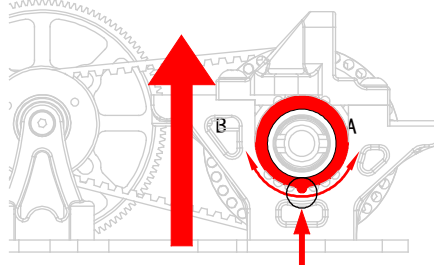

**INITIAL POSITION Ausgangslage**  
PLACE TAB IN THIS BOTTOM NOTCH Nase in die untere Kerbe einlegen

**12** Side Panel On The Cover  
Achshalterung

**Bag-B**

TR1008  
Side Panel On The Cover  
Achshalterung oben

BS308/T01114  
M3x8 Screw  
M3x8 Schraube

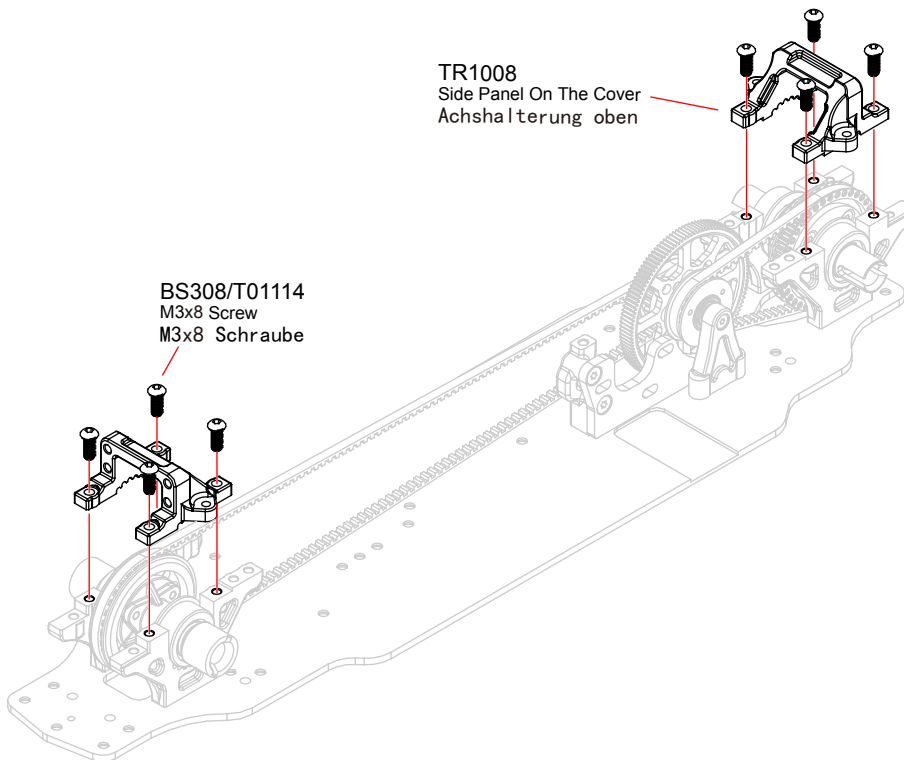

BS308/T01114 M3x8 Screw  
M3x8 Schraube



**13** Front&Rear Shock Tower  
Dämpferbrücke v/h

**Bag-B**

TR1002  
Front Shock Tower  
Dämpferbrücke vorne

BS310/T01115  
M3x10 Screw  
M3x10 Schraube

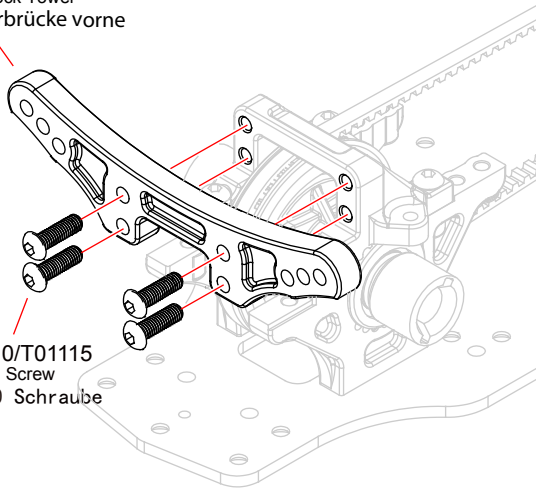

TR1002  
Rear Shock Tower  
Dämpferbrücke hinten

BS310/T01115  
M3x10 Screw  
M3x10 Schraube

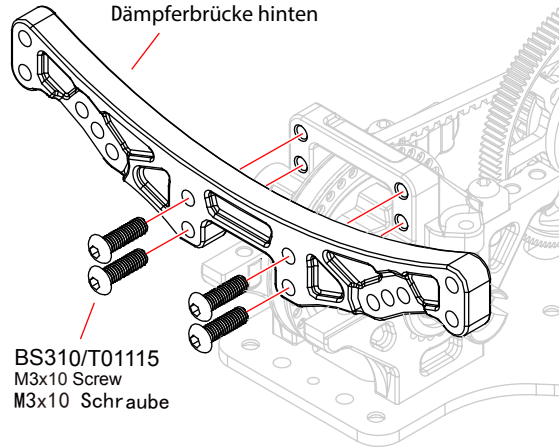

BS310/T01115 M3x10 Screw  
M3x10 Schraube



**14** Front Lower Arm  
Querlenker v

**Bag-C**

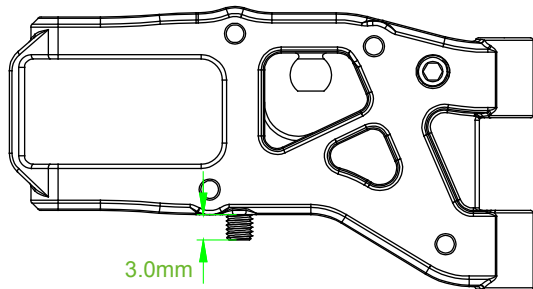
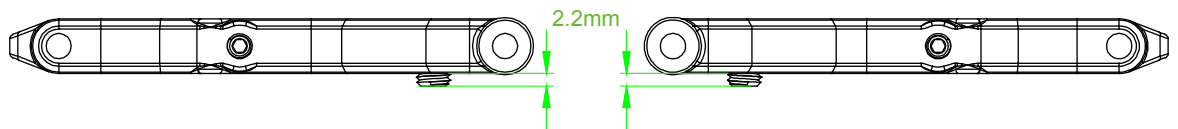

T01081  
Front Lower Arm-L  
Querlenker V-L

SS408/T01096  
M4x8 Screw  
M4x8 Schraube

T01081  
Front Lower Arm-R  
Querlenker V-R

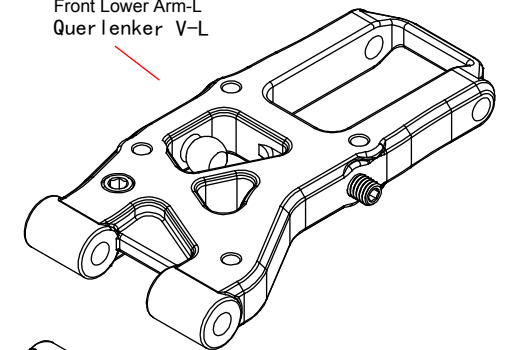

SS308/T01095  
M3x8 Screw  
M3x8 Schraube

SS408/T01096 M4x8 Screw  
M4x8 Schraube

SS308/T01095 M3x8 Screw  
M3x8 Schraube

Apply threadlocker(screw cement)  
Schraubensicherungslack verwenden

Assemble both Left and Right  
L/R gleich montieren

**15** Rear Lower Arm  
Querlenker h **Bag-C**

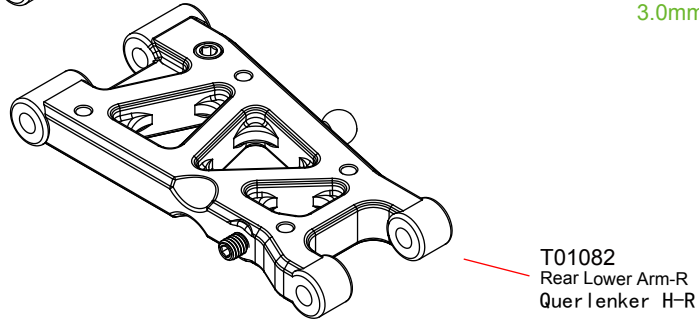
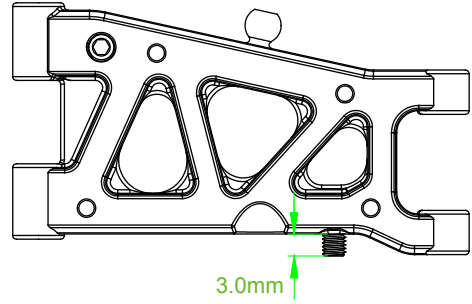
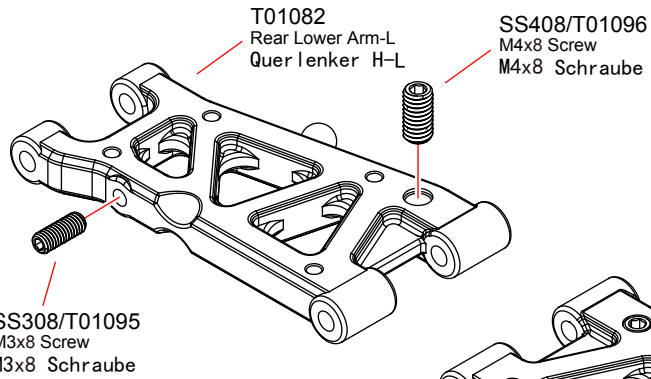
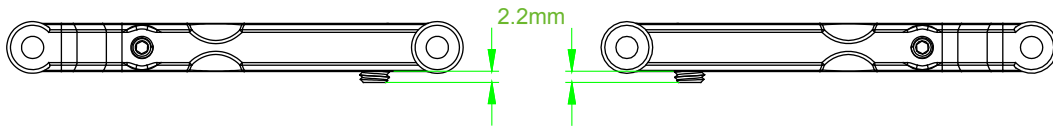

- |  |        |
|--|--------|
| SS408/T01096 M4x8 Screw<br>M4x8 Schraube | .....2 |
| SS308/T01095 M3x8 Screw<br>M3x8 Schraube | .....2 |

**16** Arm Mount  
Querlenkerhalter **Bag-C**

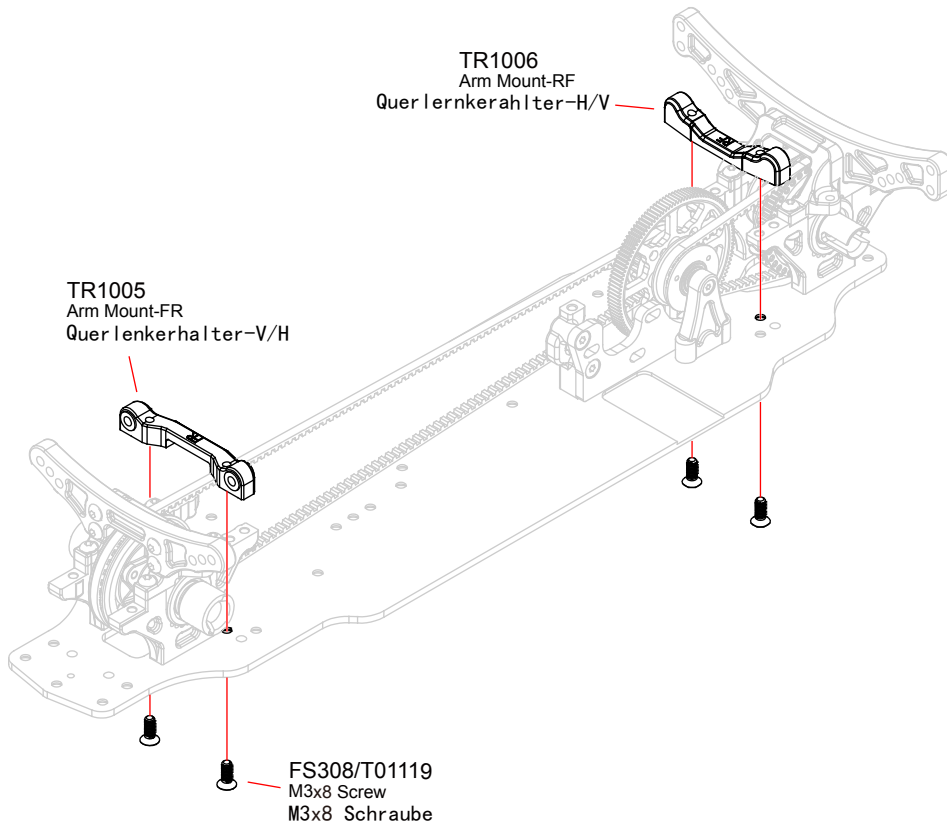

- |  |        |
|--|--------|
| FS308/T01119 M3x8 Screw<br>M3x8 Schraube | .....4 |
|--|--------|

**17** Front Lower Arm  
Querlenker V

**Bag-C**

FS308/T01119 M3x8 Screw  
M3x8 Schraube

 .....2

TR1036 Front Arm PIN-41mm  
Querlenker V Pin-41mm

 .....2

W3551/T01014 3x5.5x1 Washer  
3x5.5x1 Beilagscheibe

 .....2

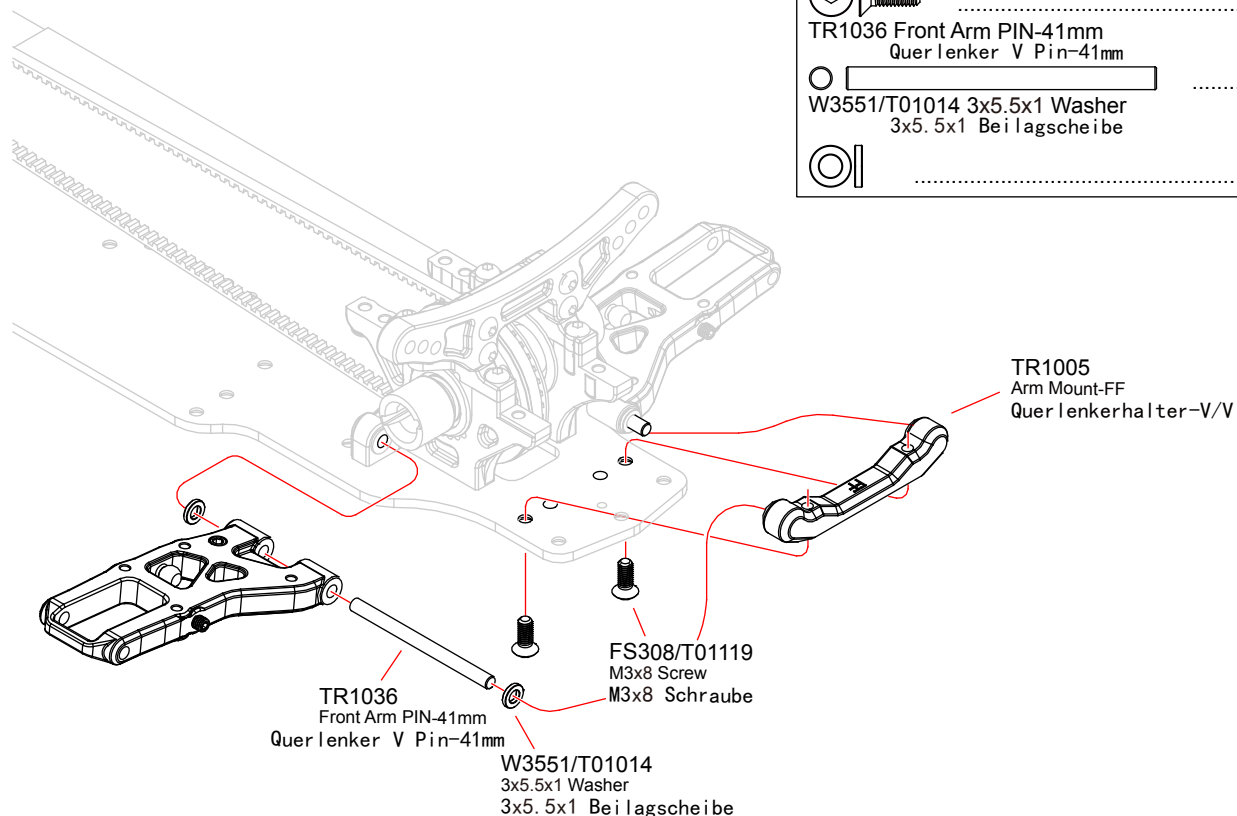

**18** Rear Lower Arm  
Querlenker H

**Bag-C**

TR1035 Rear Arm PIN-44mm  
Querlenker H Pin-44mm

 .....2

W3552/T01015 3x5.5x2 Washer  
3x5.5x2 Beilagscheibe

 .....2

W3551/T01014 3x5.5x1 Washer  
3x5.5x1 Beilagscheibe

 .....2

FS308/T01119 M3x8 Screw  
M3x8 Schraube

 .....2

TR1006  
Arm Mount-RR  
Querlenkerhalter-H/H

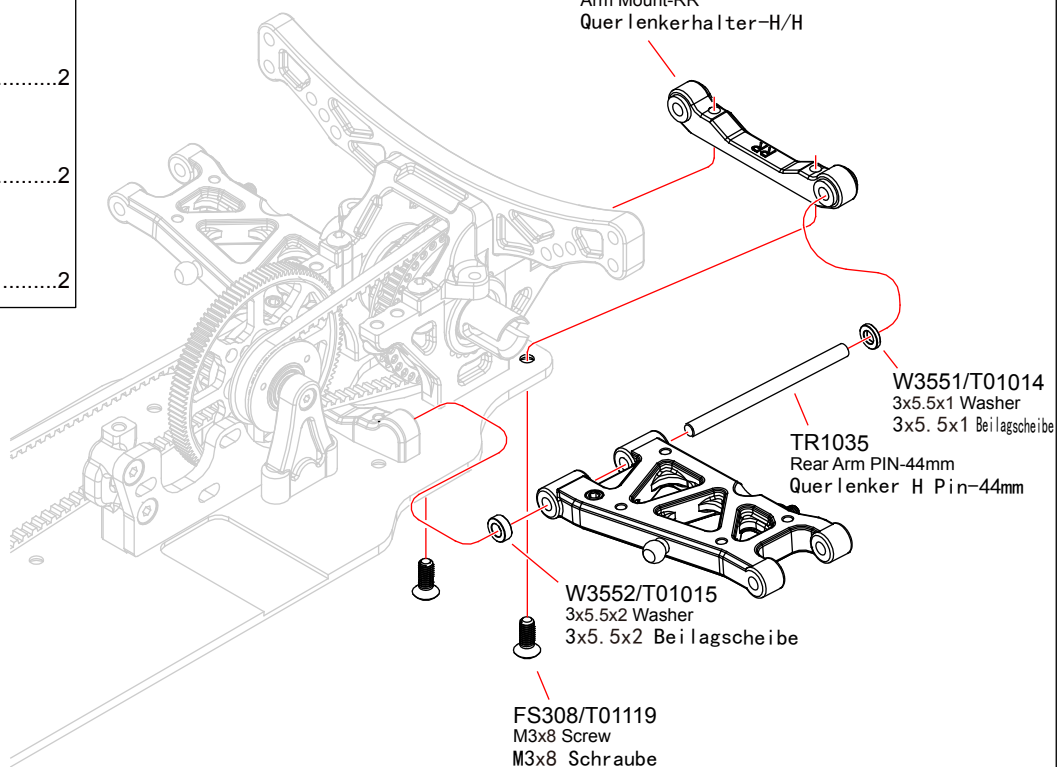

**19** Turnbuckle  
Gewindestangen

**Bag-D**

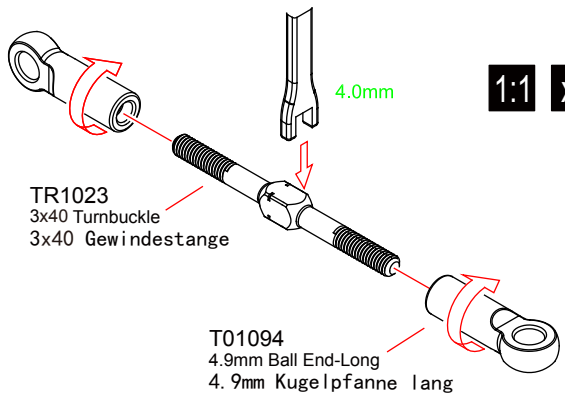
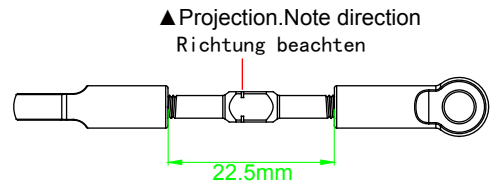
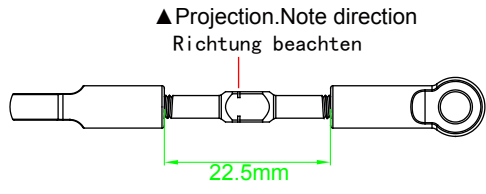

**1:1** **x1** Draglink-Left  
Lenkgestänge Links

**1:1** **x1** Draglink-Right  
Lenkgestänge Rechts

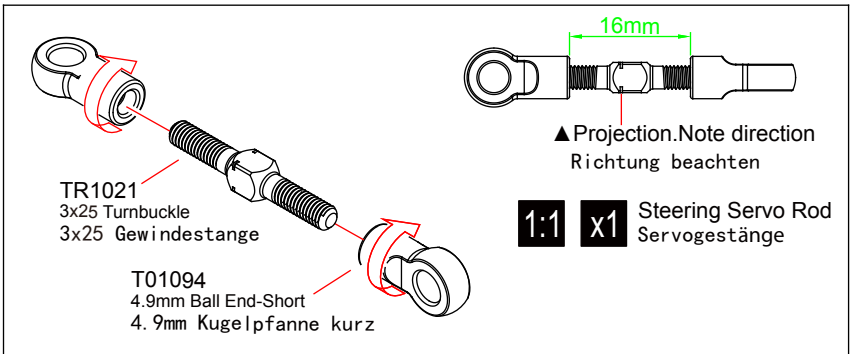

**1:1** **x1** Steering Servo Rod  
Servogestänge

TR1023 3x40 Turnbuckle 3x40 Gewindestange	.....2	TR1021 3x25 Turnbuckle 3x25 Gewindestange	.....1
T01094 4.9mm Ball End-Long 4.9mm Kugelpfanne lang	.....4	T01094 4.9mm Ball End-Short 4.9mm Kugelpfanne kurz	.....2

**20** Steering System  
Lenksystem

**Bag-D**

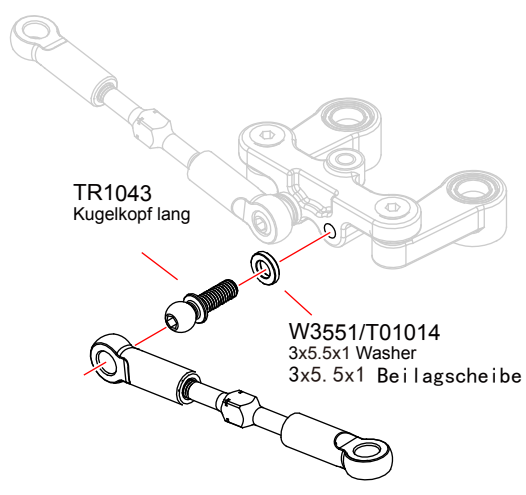
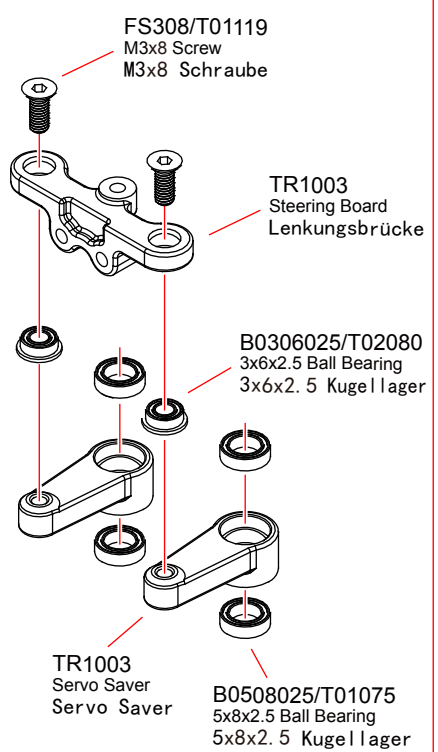

B0508025/T01075 5x8x2.5 Ball Bearing 5x8x2.5 Kugellager	.....4
B0306025/T02080 3x6x2.5 Ball Bearing 3x6x2.5 Kugellager	.....2
FS308/T01119 M3x8 Screw M3x8 Schraube	.....2
W3551/T01014 3x5.5x1 Washer 3x5.5x1 Beilagscheibe	.....2
TR1043 Ball Stud-Long Kugelkopf lang	.....2

**1:1** True-to-scale diagram  
1:1 Zusammenbau

**x1** Assemble as many times as specified  
So oft montieren wie angegeben

Bag-D

- W3554/T01016 3x5.5x4 Washer  
3x5.5x4 Beilagscheibe
- TR1043 Ball Stud-Long  
Kugelhkopf lang

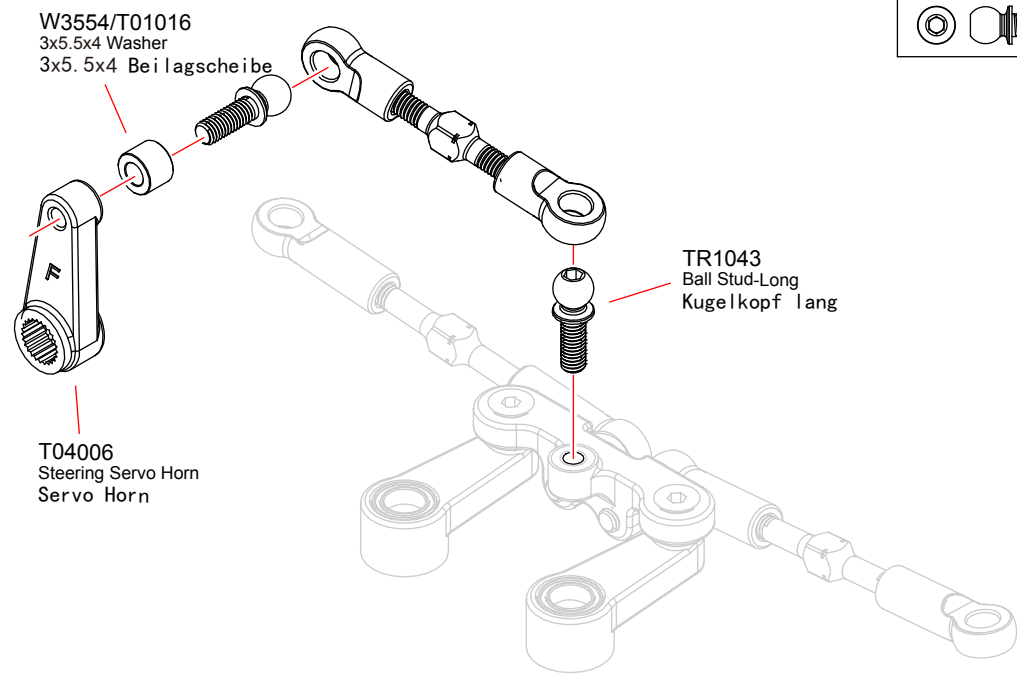

W3554/T01016  
3x5.5x4 Washer  
3x5.5x4 Beilagscheibe

T04006  
Steering Servo Horn  
Servo Horn

TR1043  
Ball Stud-Long  
Kugelhkopf lang

Bag-D

- BS308/T01114 M3x8 Screw  
M3x8 Schraube
- FS306/T01118 M3x6 Screw  
M3x6 Schraube

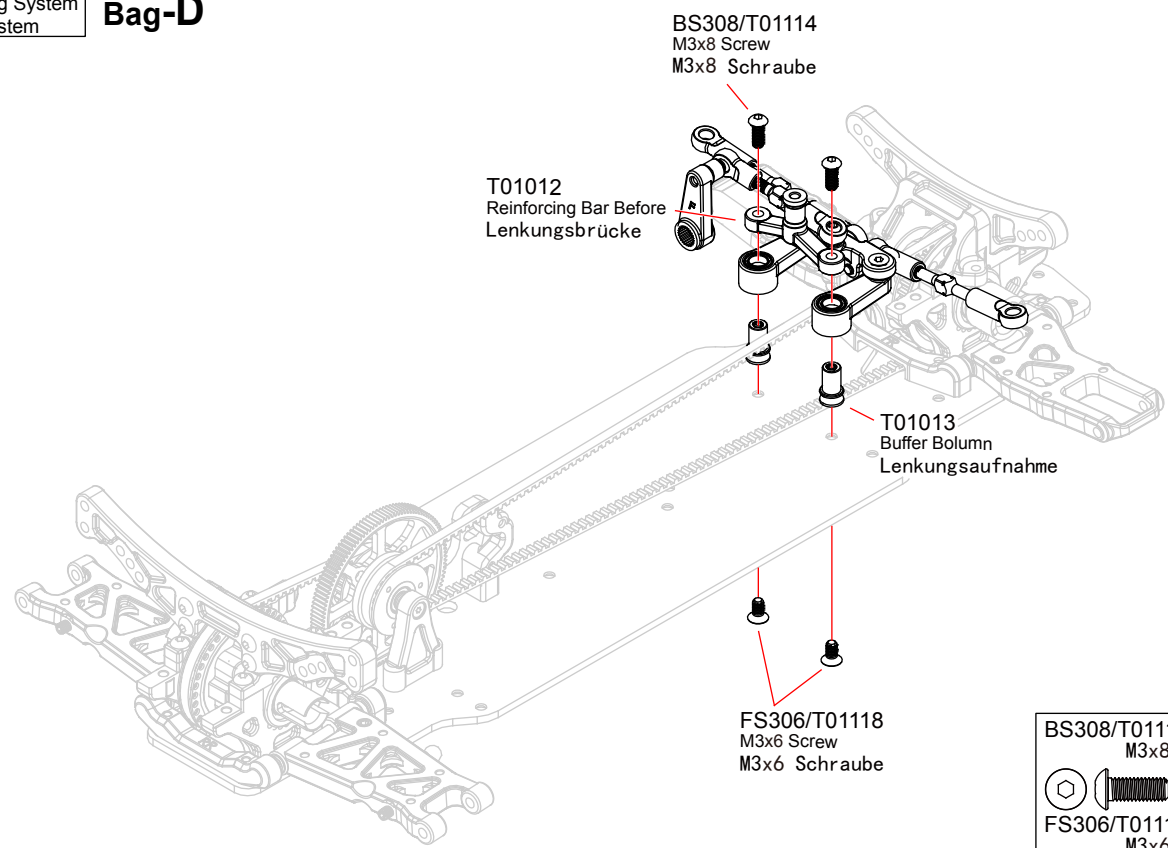

T01012  
Reinforcing Bar Before  
Lenkungsbrücke

BS308/T01114  
M3x8 Screw  
M3x8 Schraube

T01013  
Buffer Bolumn  
Lenkungsaufnahme

FS306/T01118  
M3x6 Screw  
M3x6 Schraube



**Bag-D**

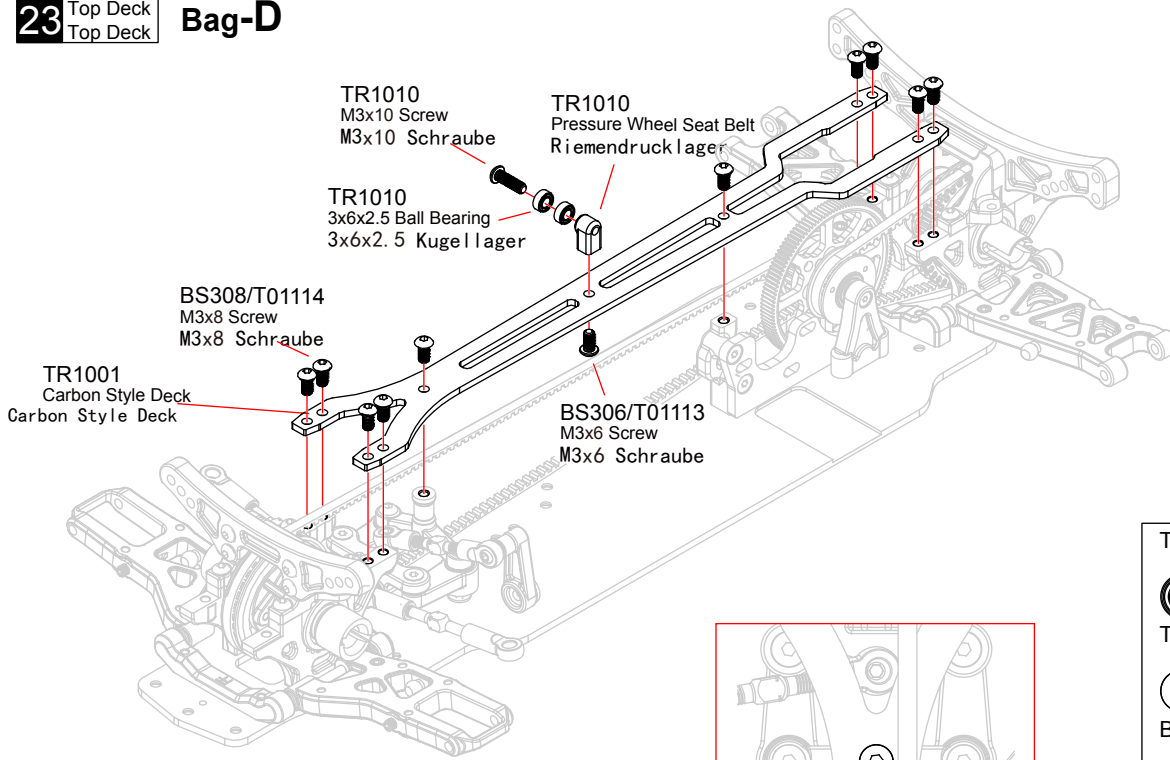

Please locking the screw, then return a quarter circle.  
Schrauben festziehen danach eine viertel Umdrehung lösen.

TR1010 3x6x2.5 Ball Bearing 3x6x2.5 Kugellager	.....2
TR1010 M3x10 Screw M3x10 Schraube	.....1
BS308/T01114 M3x8 Screw M3x8 Schraube	.....10
BS306/T01113 M3x6 Screw M3x6 Schraube	.....1

**Bag-E**

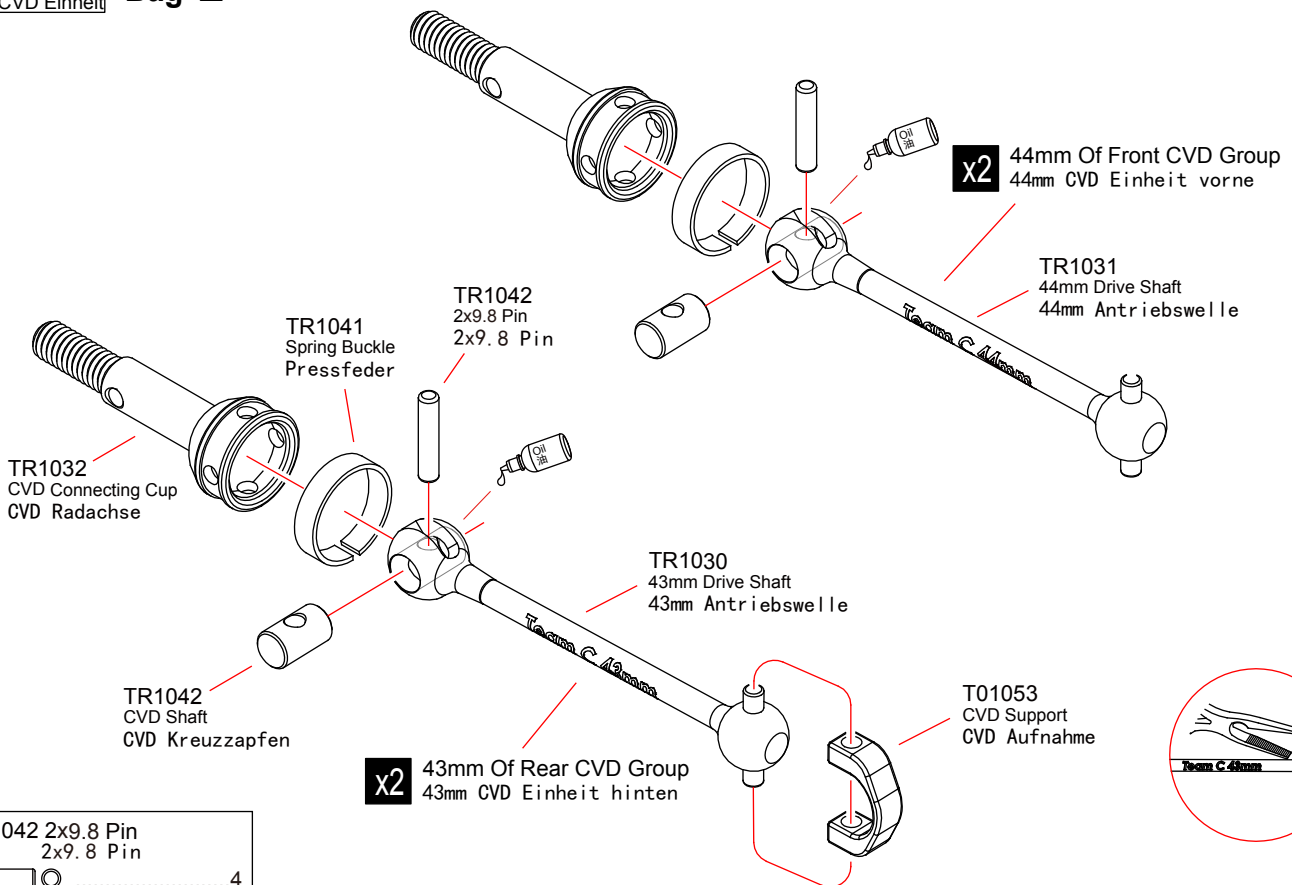

TR1042 2x9.8 Pin 2x9.8 Pin	.....4
-------------------------------	--------

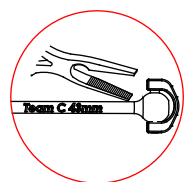

**25** Front Hub Carriers  
Hub vorne

**Bag-E x2**

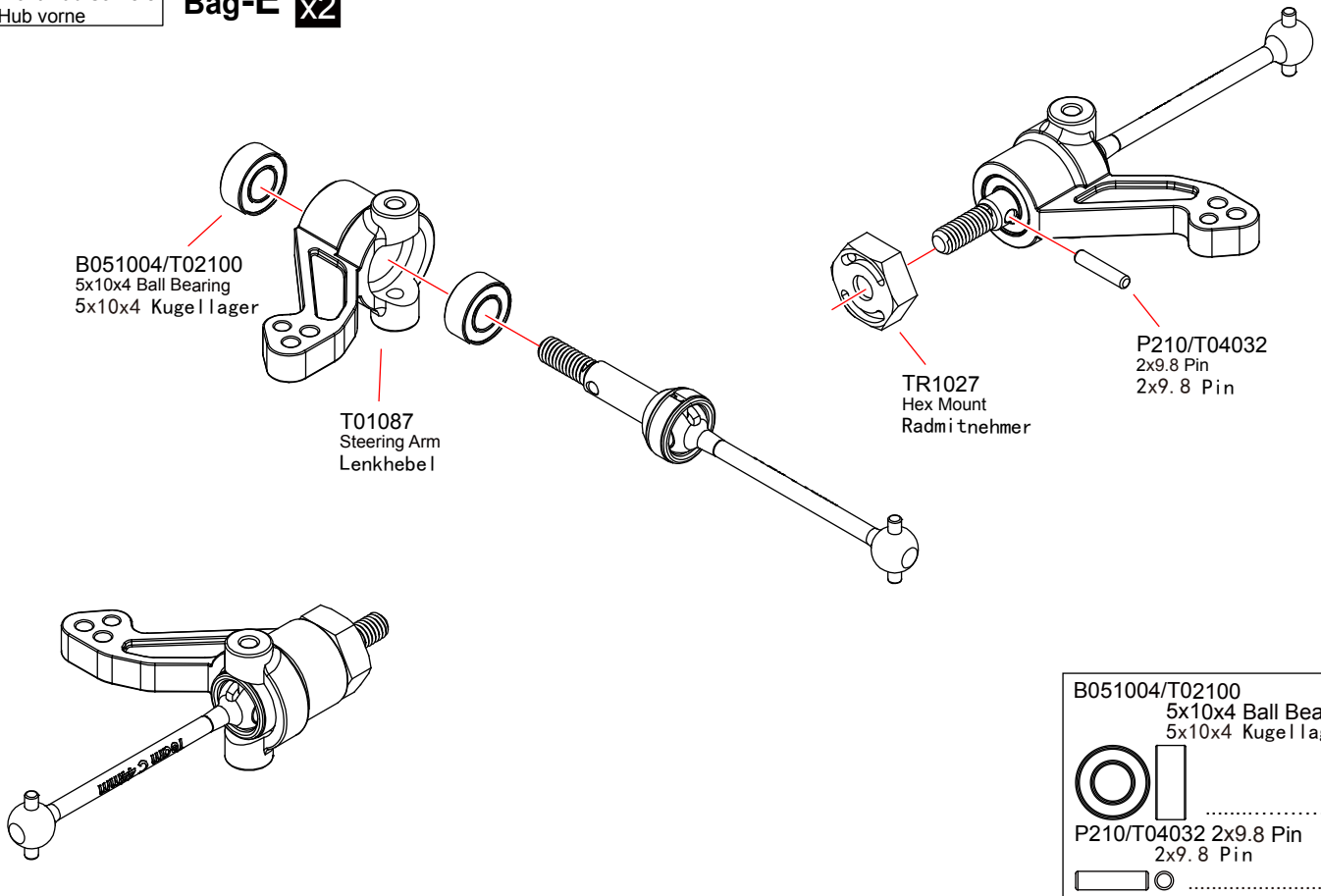

**26** Front Hub Carriers  
Hub vorne

**Bag-E x2**

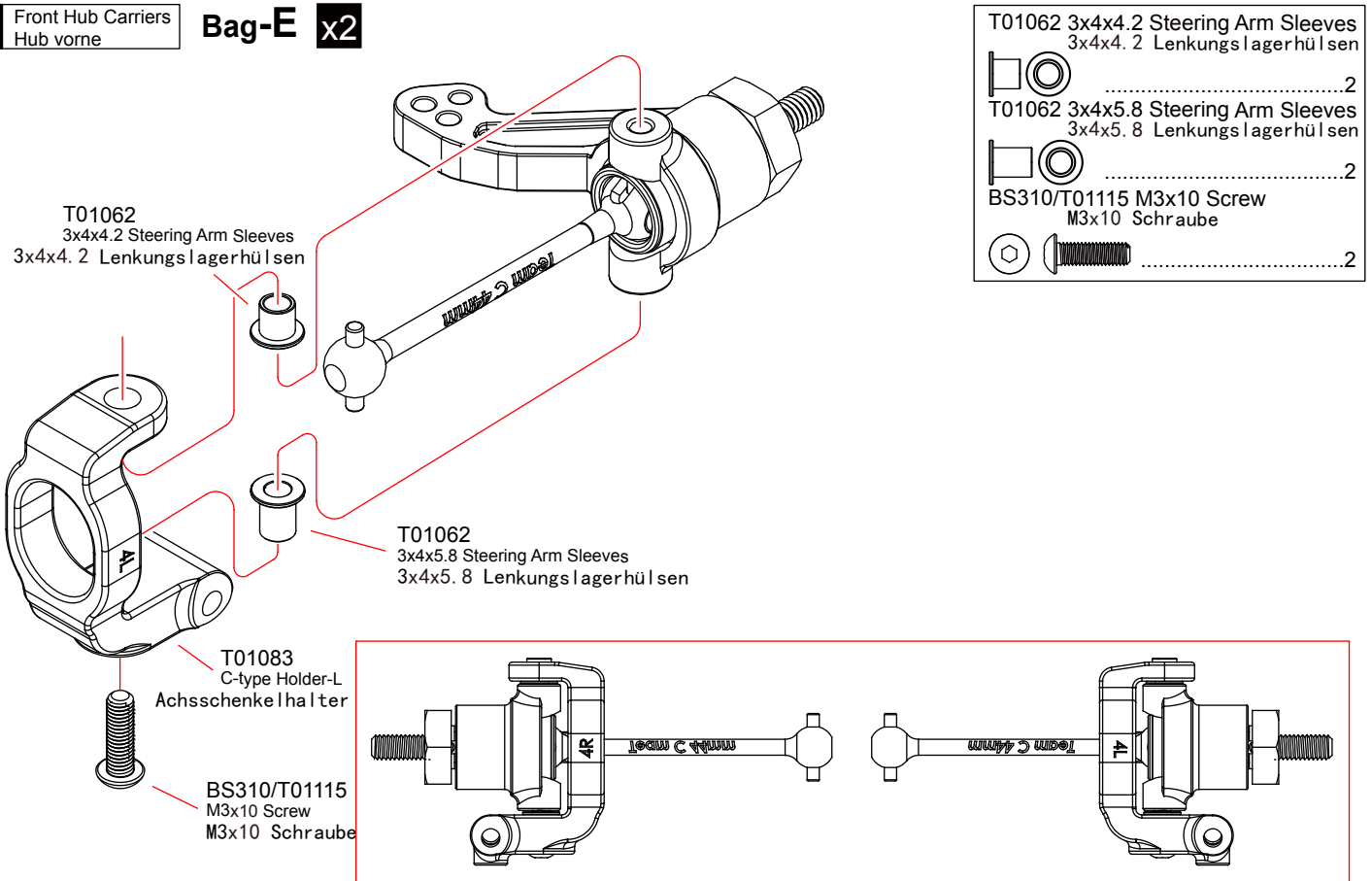

**27** Rear Hub Carriers  
Hub hinten **Bag-E** x2

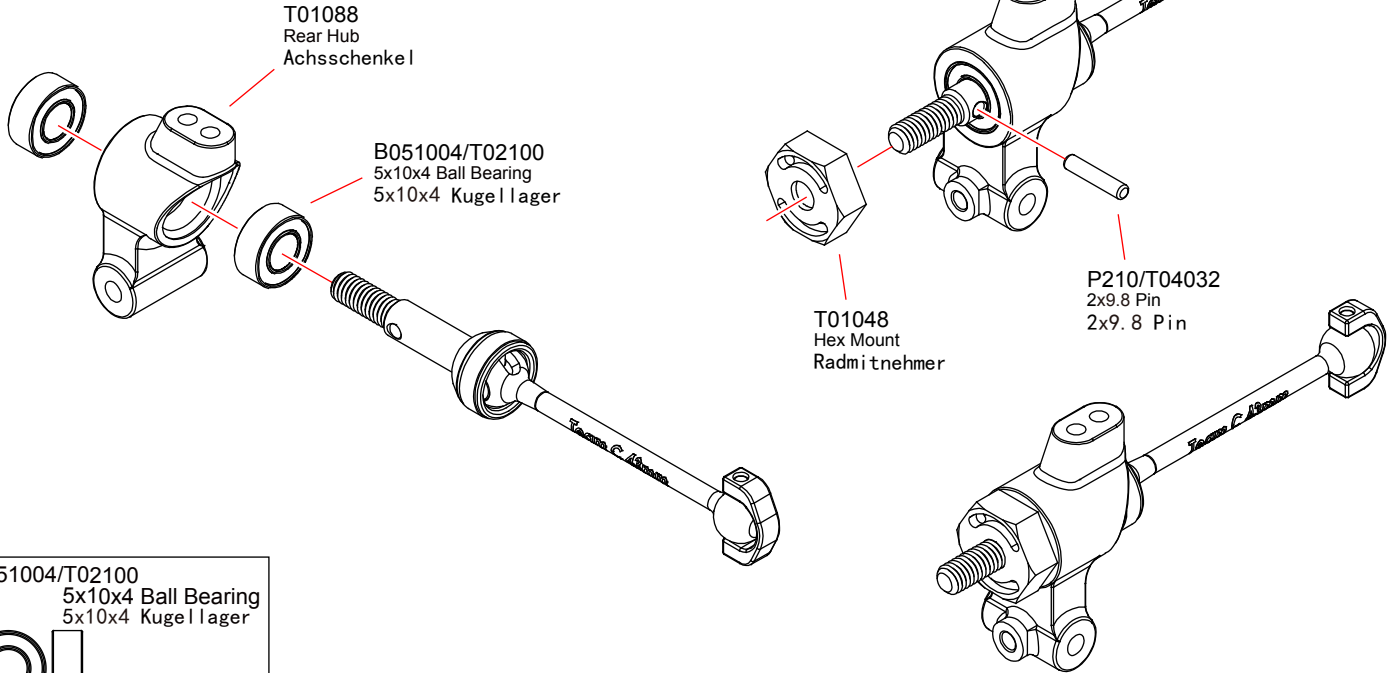

B051004/T02100	
5x10x4 Ball Bearing	
5x10x4 Kugellager	
	.....4
P210/T04032 2x9.8 Pin	
2x9.8 Pin	
	.....2

**28** Turnbuckle  
Gewindestange **Bag-E**

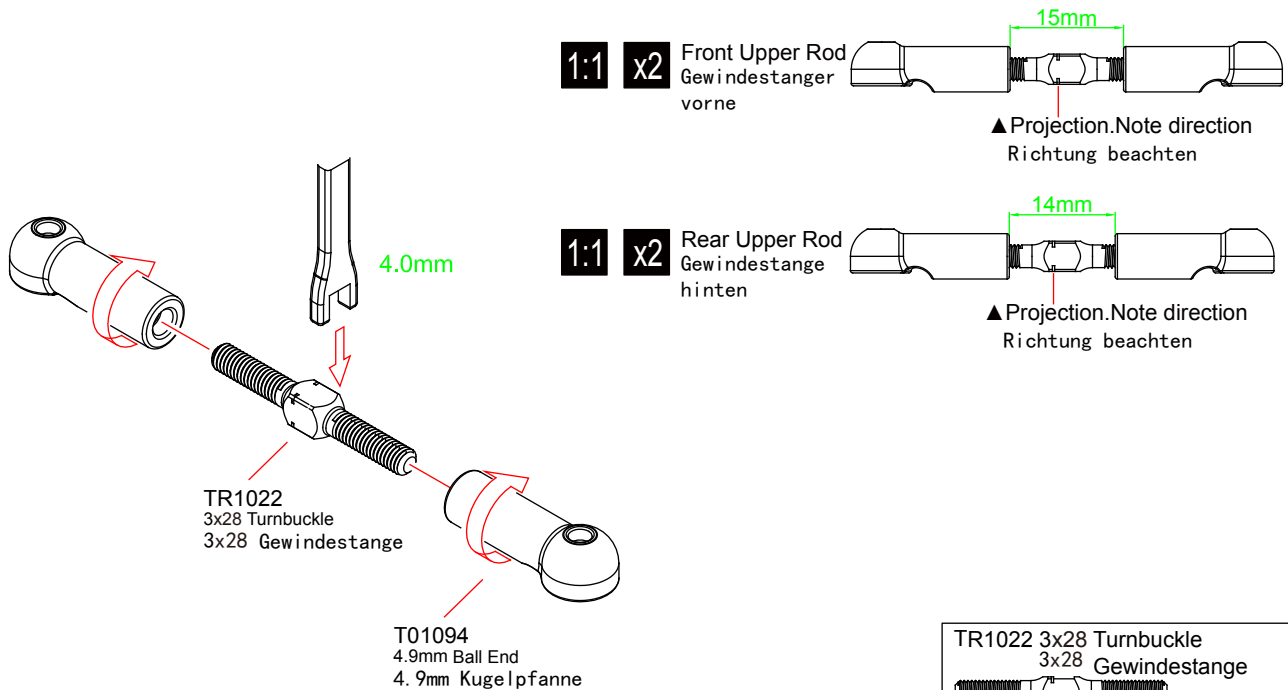

**1:1** x2 Front Upper Rod  
Gewindestanger  
vorne

▲ Projection. Note direction  
Richtung beachten

**1:1** x2 Rear Upper Rod  
Gewindestange  
hinten

▲ Projection. Note direction  
Richtung beachten

TR1022  
3x28 Turnbuckle  
3x28 Gewindestange

T01094  
4.9mm Ball End  
4.9mm Kugelpfanne

TR1022 3x28 Turnbuckle	
3x28 Gewindestange	
	.....4
T01094 4.9mm Ball End	
4.9mm Kugelpfanne	
	.....8

**29** Front Suspension Arm  
Aufhängung vorne

**Bag-E**

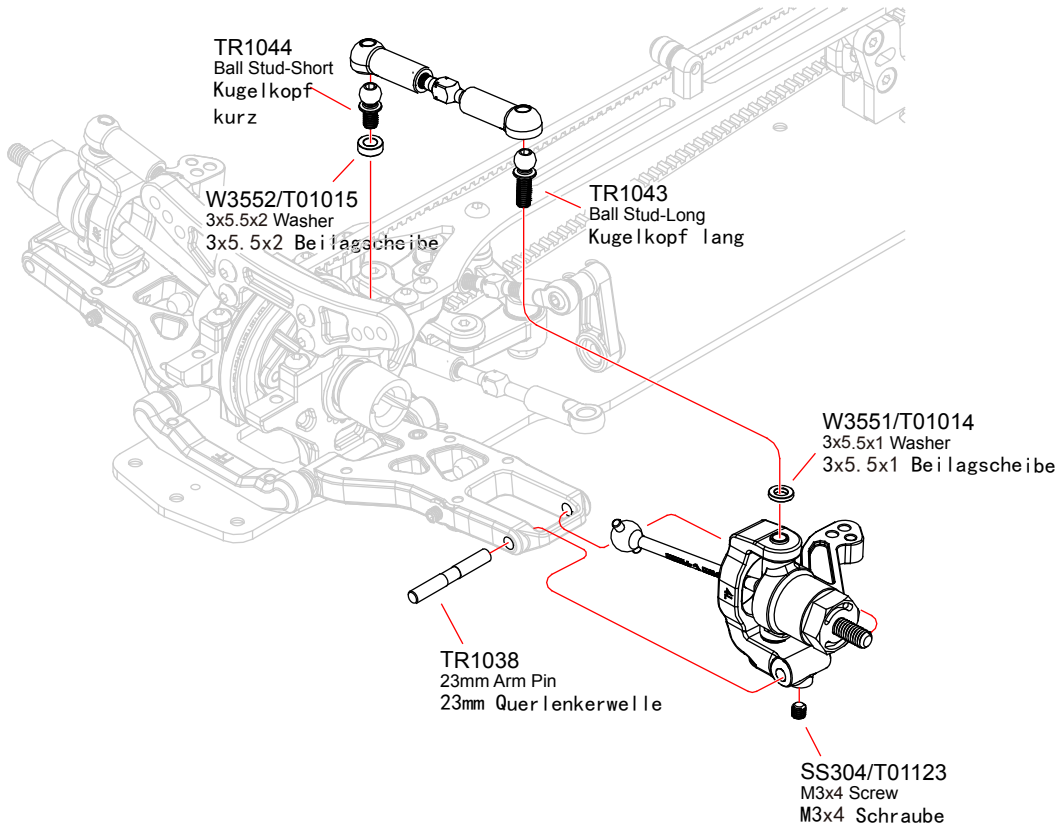

W3552/T01015 3x5.5x2 Washer 3x5.5x2 Beilagscheibe		.....2
W3551/T01014 3x5.5x1 Washer 3x5.5x1 Beilagscheibe		.....2
TR1043 Ball Stud-Long Kugelkopf lang		.....2
TR1044 Ball Stud-Short Kugelkopf kurz		.....2
SS304/T01123 M3x4 Screw M3x4 Schraube		.....2
TR1038 23mm Arm Pin 23mm Querlenkerwelle		.....2

**30** Rear Suspension Arm  
Aufhängung hinten

**Bag-E**

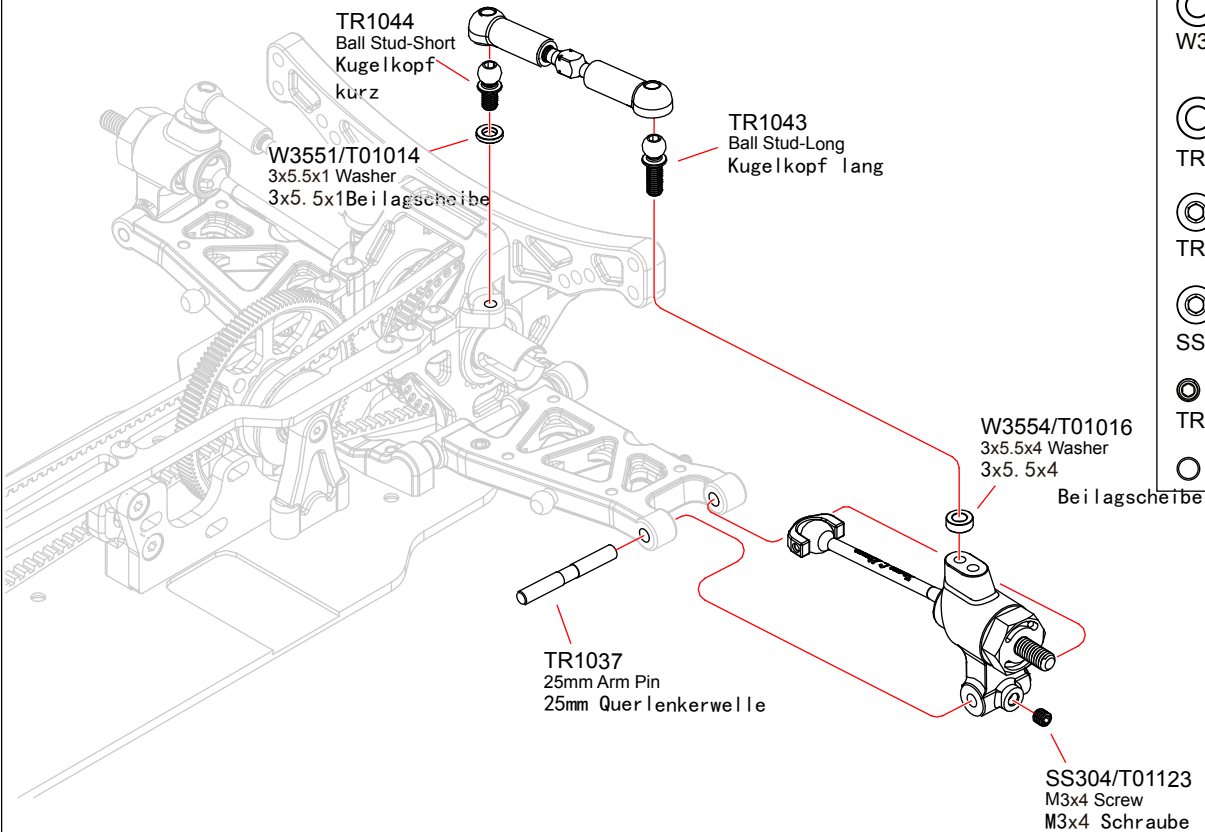

W3554/T01016 3x5.5x4 Washer 3x5.5x4 Beilagscheibe		.....2
W3551/T01014 3x5.5x1 Washer 3x5.5x1 Beilagscheibe		.....2
TR1043 Ball Stud-Long Kugelkopf lang		.....2
TR1044 Ball Stud-Short Kugelkopf kurz		.....2
SS304/T01123 M3x4 Screw M3x4 Schraube		.....2
TR1037 25mm Arm Pin 25mm Querlenkerwelle		.....2

Assemble both Left and Right  
L/R gleich montieren

**31** Servo Arm  
Servo Arm **Bag-E**

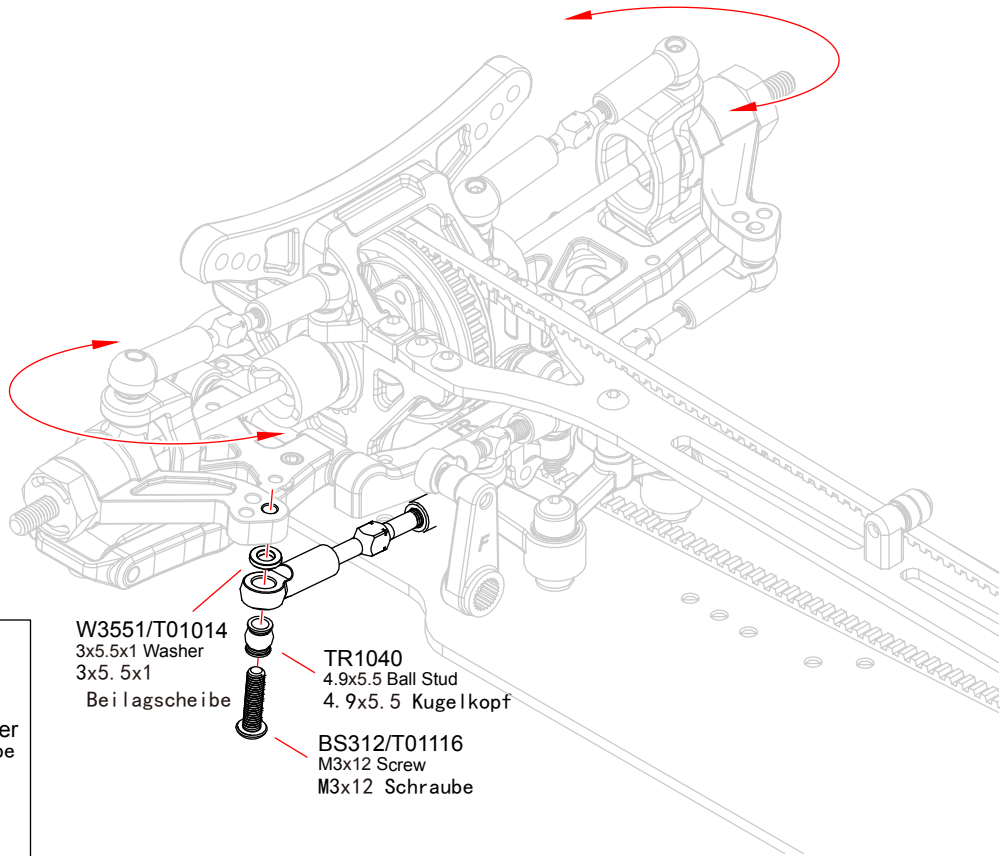

TR1040 4.9x5.5 Ball Stud  
4.9x5.5 Kugelkopf

.....2

W3551/T01014 3x5.5x1 Washer  
3x5.5x1 Beilagscheibe

.....2

BS312/T01116 M3x12 Screw  
M3x12 Schraube

.....2

W3551/T01014  
3x5.5x1 Washer  
3x5.5x1  
Beilagscheibe

TR1040  
4.9x5.5 Ball Stud  
4.9x5.5 Kugelkopf

BS312/T01116  
M3x12 Screw  
M3x12 Schraube

**32** Shock Absorber  
Dämpfer **Bag-F** **x4**

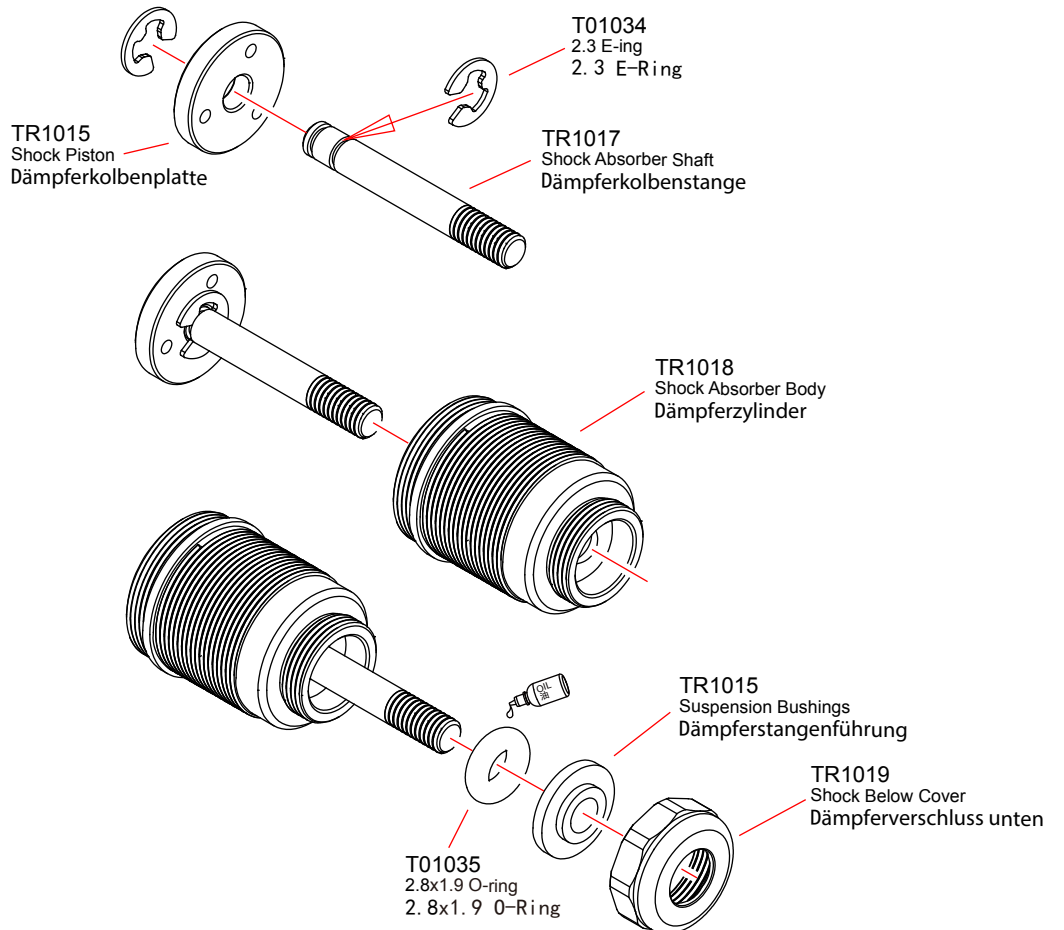

TR1015  
Shock Piston  
Dämpferkolbenplatte

T01034  
2.3 E-ing  
2.3 E-Ring

TR1017  
Shock Absorber Shaft  
Dämpferkolbenstange

TR1018  
Shock Absorber Body  
Dämpferzylinder

TR1015 Shock Piston  
Dämpferkolbenplatte

.....4

T01034 2.3 E-ing  
2.3 E-Ring

.....8

T01035 2.8x1.9 O-Ring  
2.8x1.9 O-Ring

.....4

TR1015  
Suspension Bushings  
Dämpferstangenführung

TR1019  
Shock Below Cover  
Dämpferverschluss unten

T01035  
2.8x1.9 O-ring  
2.8x1.9 O-Ring

**33** Shock Absorber  
Dämpfer

**Bag-F** **x4**

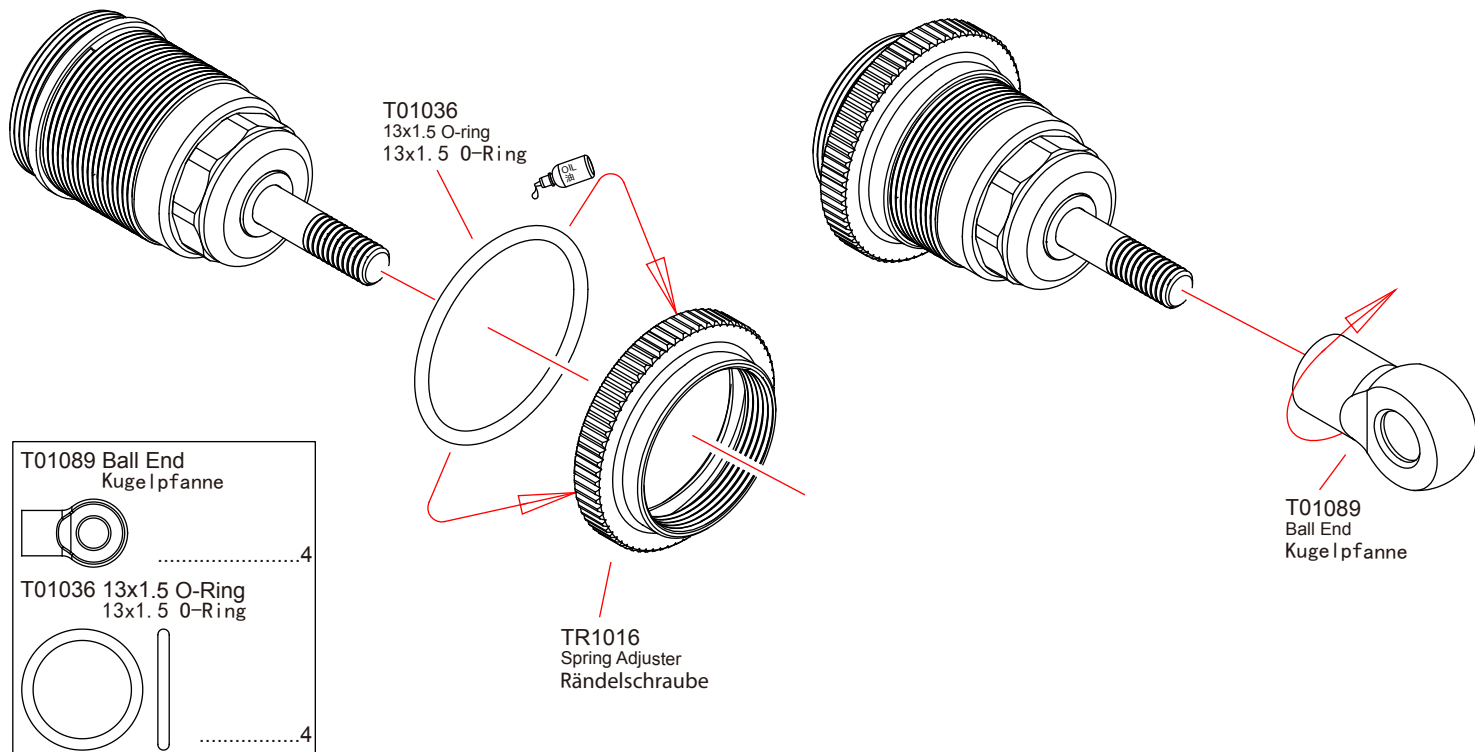

**34** Shock Absorber  
Dämpfer

**Bag-F** **x4**

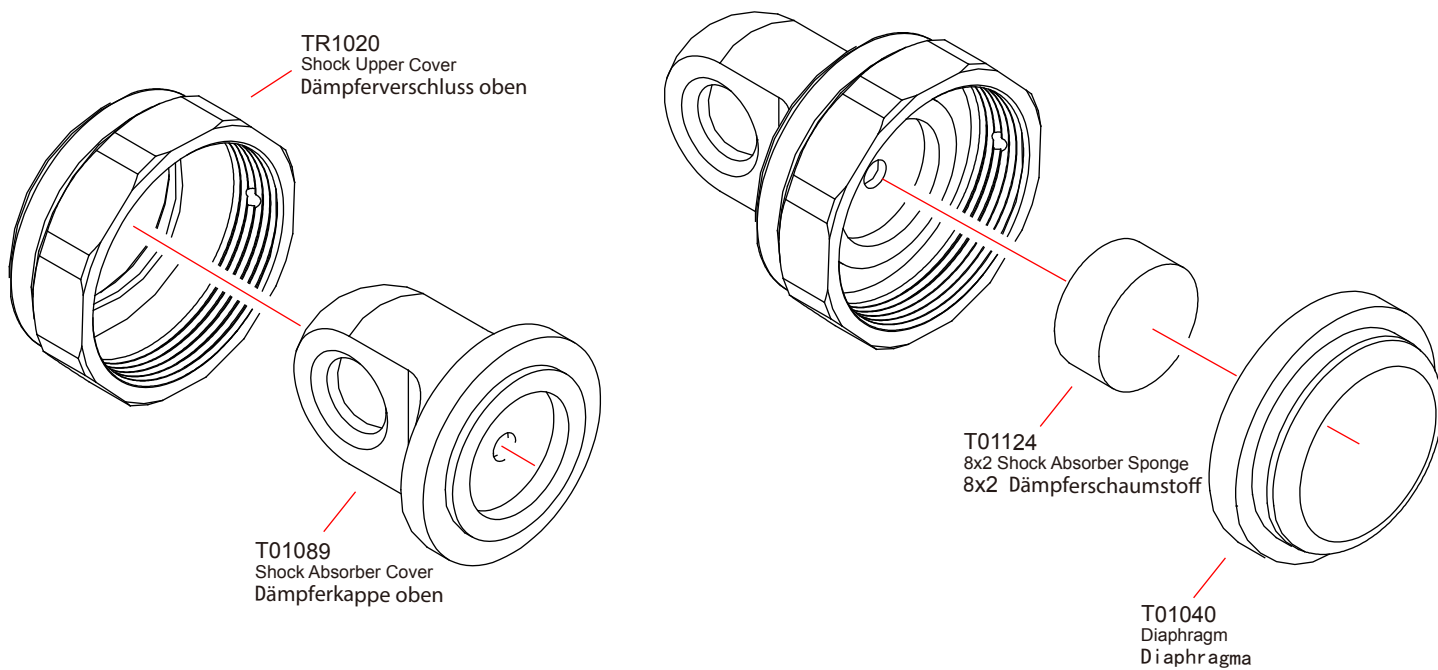

**35** Shock Absorber  
Dämpfer

**Bag-F x4**

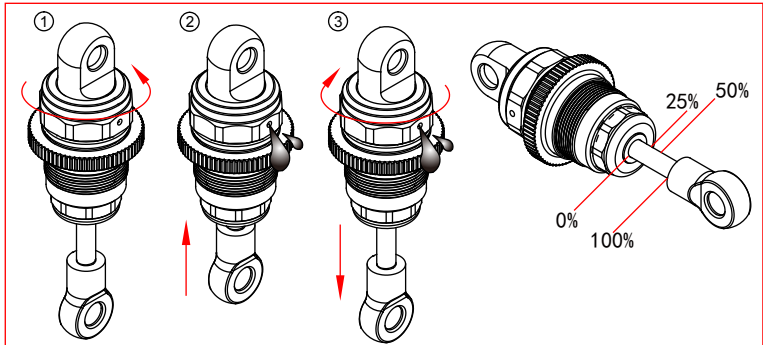
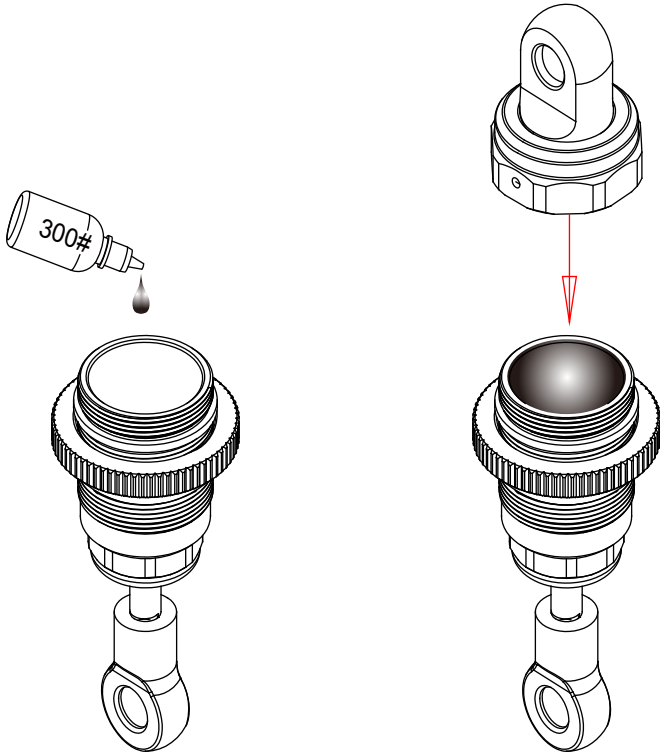

After the shock is assembled you have to set the shock rebound.  
Nach dem Zusammenbau müssen Sie den Dämpfer Rebound einstellen.

- ① Release the shock cap by 2-3 turns.  
Lösen Sie die Dämpferkappe mit 2-3 Umdrehungen.
- ② Push the shock shaft fully up .For the first time the extra oil will release through the hole in the alu cap-nut. Drücken Sie die Dämpferstange komplett nach oben. Beim ersten mal wird etwas Öl aus dem kleinen Loch entweichen.
- ③ Tighten the shock cup .When tightening the shock cup,extra oil will again release through the hole in the alu cap-nut.When tightening,the shock shaft will push out from the shock body. Dämpferkappe wieder festziehen. Wenn Sie die Dämpferkappe festziehen wird ein bisschen Öl wieder aus dem kleinen Loch austreten. Beim festziehen wird die Gewindestange wieder nach unten gedrückt.

**36** Shock Absorber  
Dämpfer

**Bag-F x4**

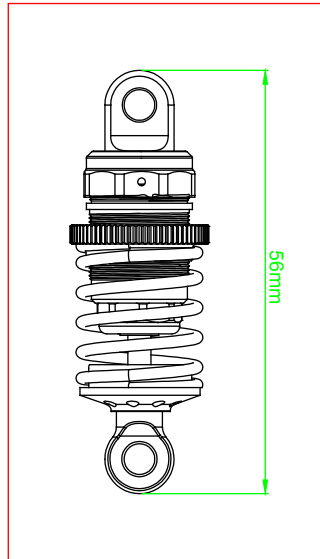
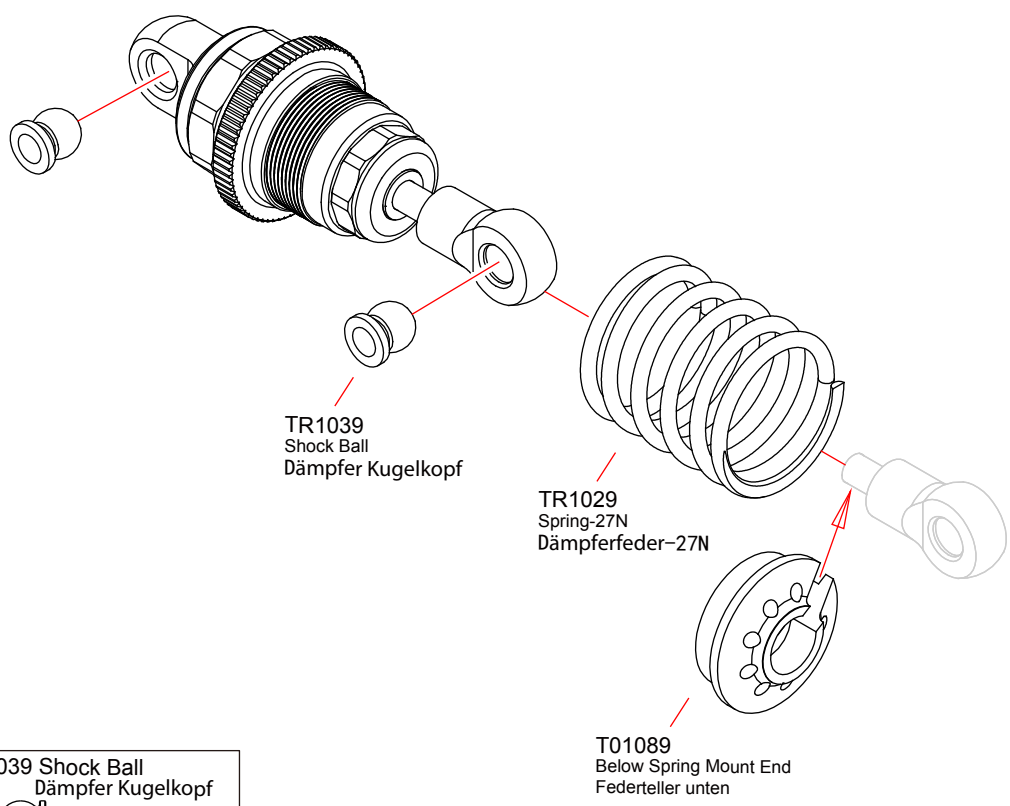

TR1039 Shock Ball  
Dämpfer Kugelkopf  
.....8

T01089  
Below Spring Mount End  
Federteller unten

**37** Front Bumper Set  
Front Rammer Set **Bag-G**

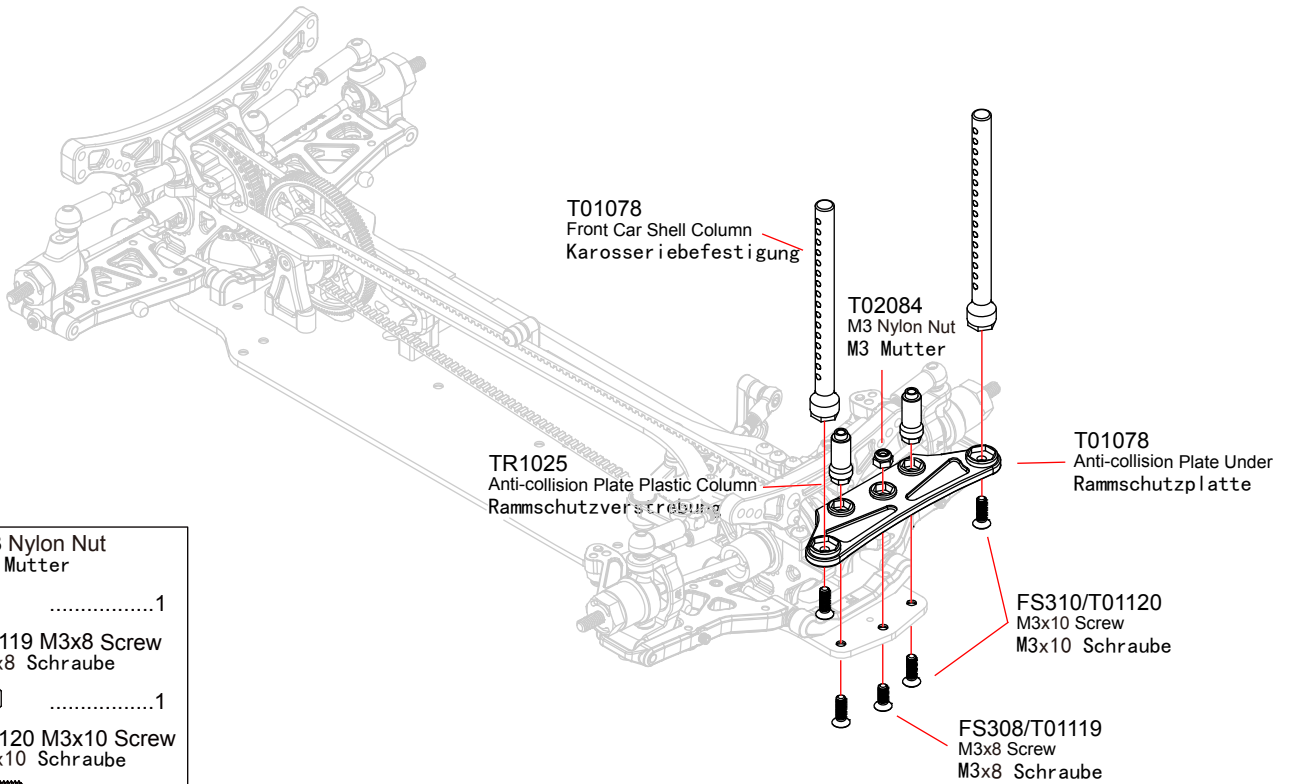

- |  |  |        |
|--|--|--------|
|  | T02084 M3 Nylon Nut<br>M3 Mutter           | .....1 |
|  | FS308/T01119 M3x8 Screw<br>M3x8 Schraube   | .....1 |
|  | FS310/T01120 M3x10 Screw<br>M3x10 Schraube | .....4 |

**38** Front Bumper Set  
Front Rammer Set **Bag-G**

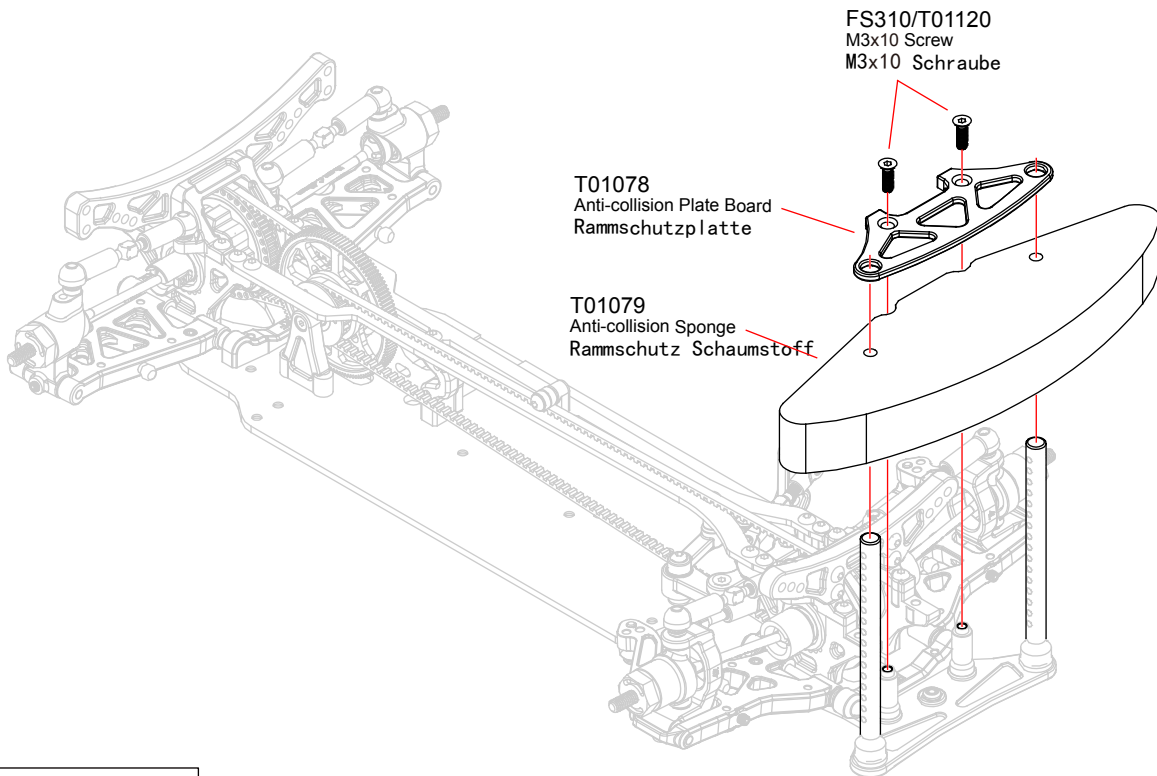

- |  |  |        |
|--|--|--------|
|  | FS310/T01120 M3x10 Screw<br>M3x10 Schraube | .....2 |
|--|--|--------|



**39** Front Body Mount  
Karosseriehalter vorne

**Bag-G**

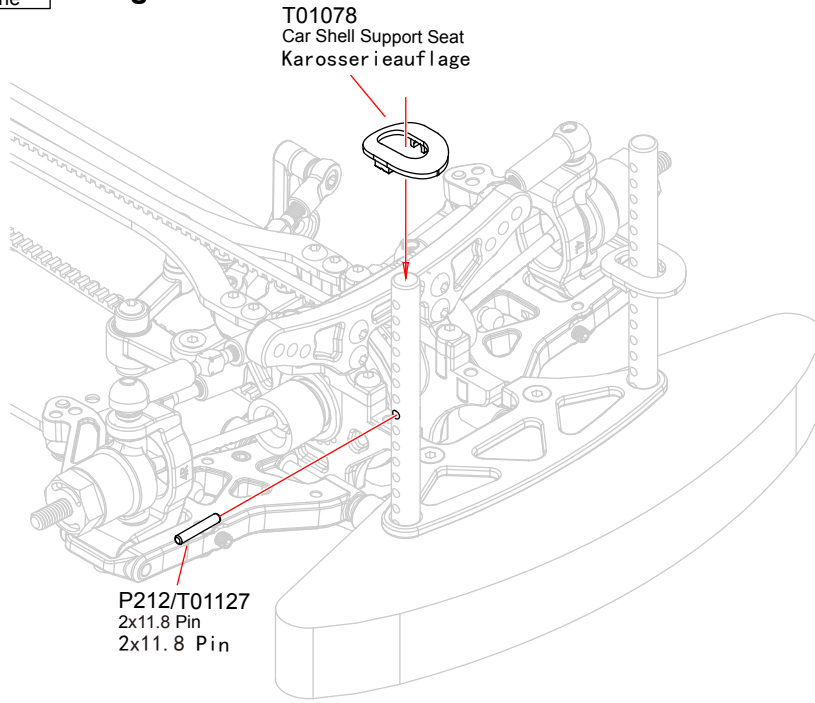

T01078  
Car Shell Support Seat  
Karosserieauflage

P212/T01127  
2x11.8 Pin  
2x11.8 Pin

P212/T01127 2x11.8 Pin  
2x11.8 Pin

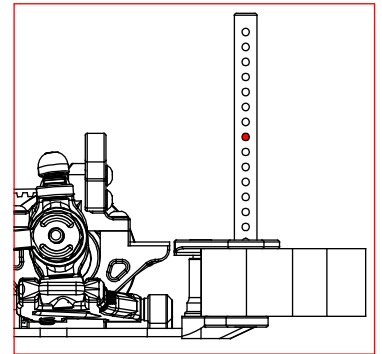
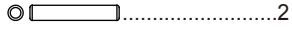

**40** Front Shock Absorber  
Dämpfer vorne

**Bag-G**

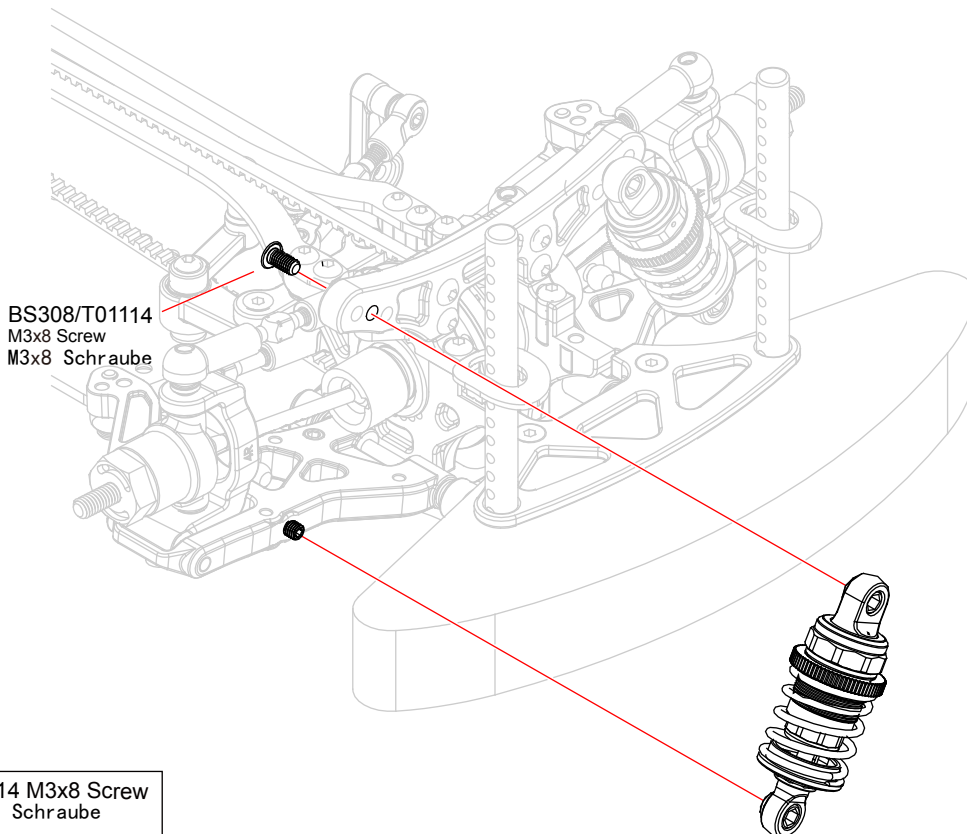

BS308/T01114  
M3x8 Screw  
M3x8 Schraube

BS308/T01114 M3x8 Screw  
M3x8 Schraube

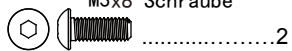

**41** Rear Body Mount  
Karosseriehalter hinten

**Bag-G**

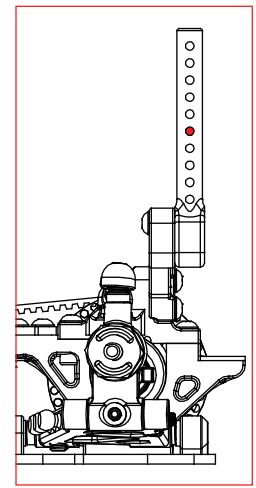
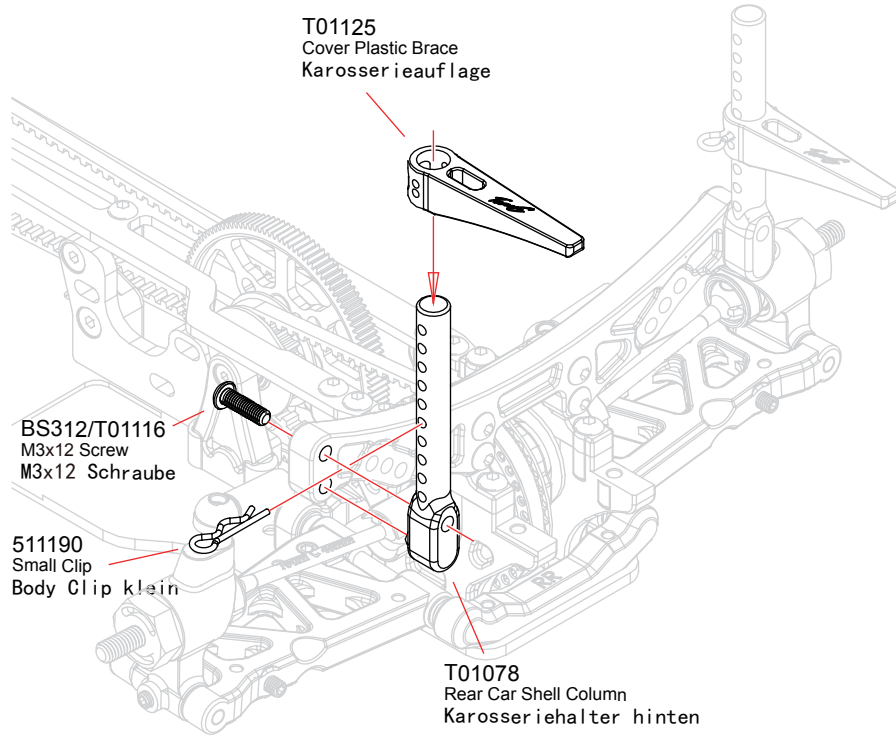

BS312/T01116  
M3x12 Screw  
M3x12 Schraube

511190  
Small Clip  
Body Clip klein

T01125  
Cover Plastic Brace  
Karosserieauflage

T01078  
Rear Car Shell Column  
Karosseriehalter hinten

BS312/T01116 M3x12 Screw  
M3x12 Schraube

 .....2

511190 Small Clip  
Body Clip klein

 .....2

**42** Rear Shock Absorber  
Dämpfer hinten

**Bag-G**

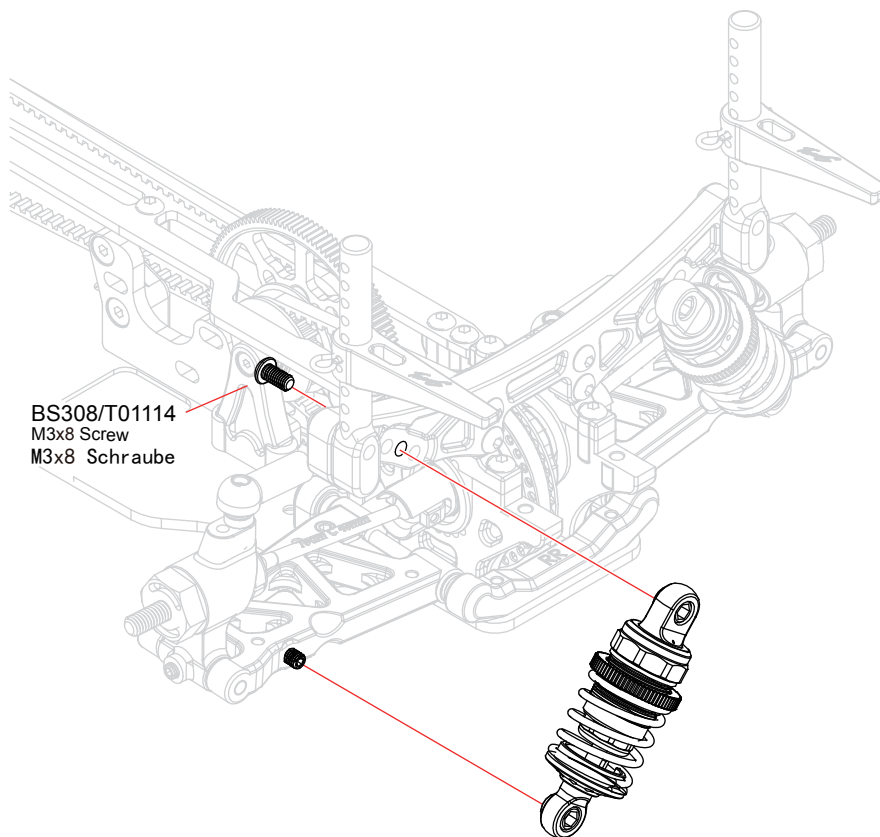

BS308/T01114  
M3x8 Screw  
M3x8 Schraube

BS308/T01114 M3x8 Screw  
M3x8 Schraube

 .....2

**43** Steering Servo  
Lenkservo **Bag-H**

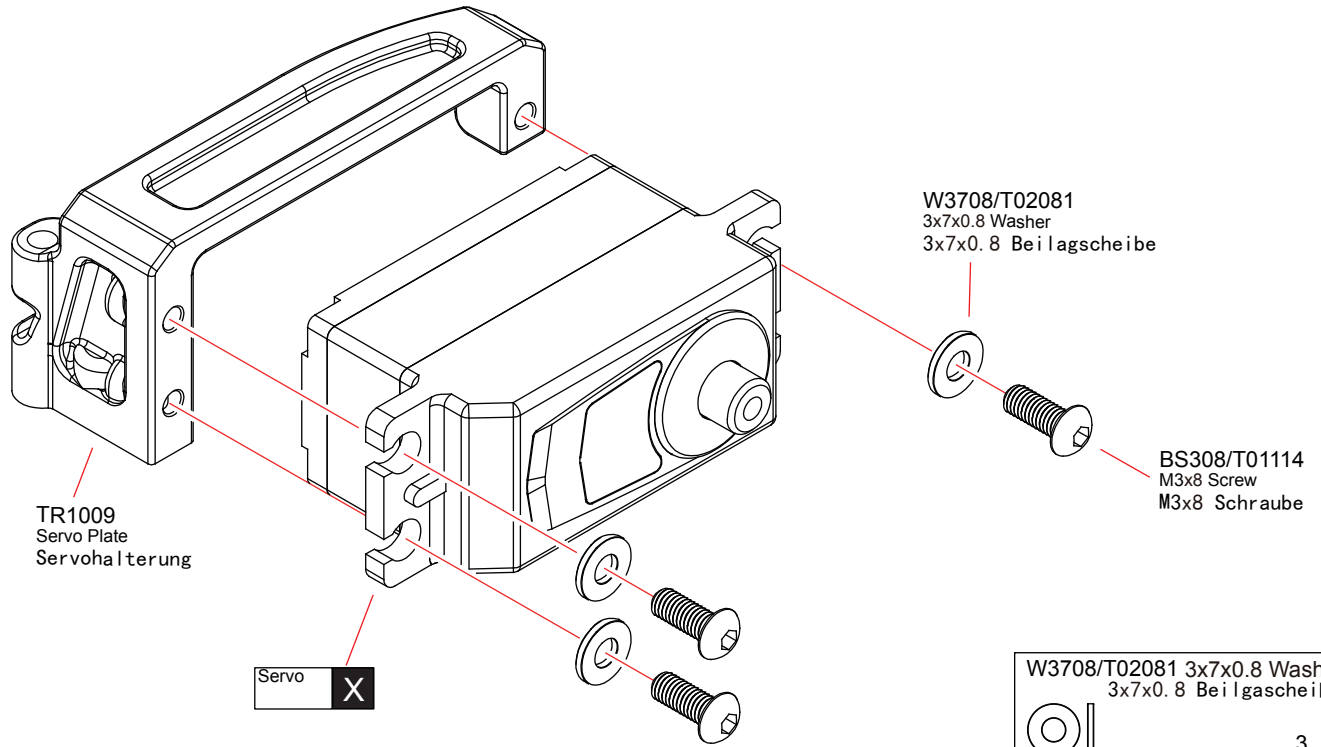

TR1009  
Servo Plate  
Servohalterung

Servo X

W3708/T02081  
3x7x0.8 Washer  
3x7x0.8 Beilagscheibe

BS308/T01114  
M3x8 Screw  
M3x8 Schraube

W3708/T02081 3x7x0.8 Washer  
3x7x0.8 Beilagscheibe

.....3

BS308/T01114 M3x8 Screw  
M3x8 Schraube

.....3

**44** Steering Servo  
Lenkservo **Bag-H**

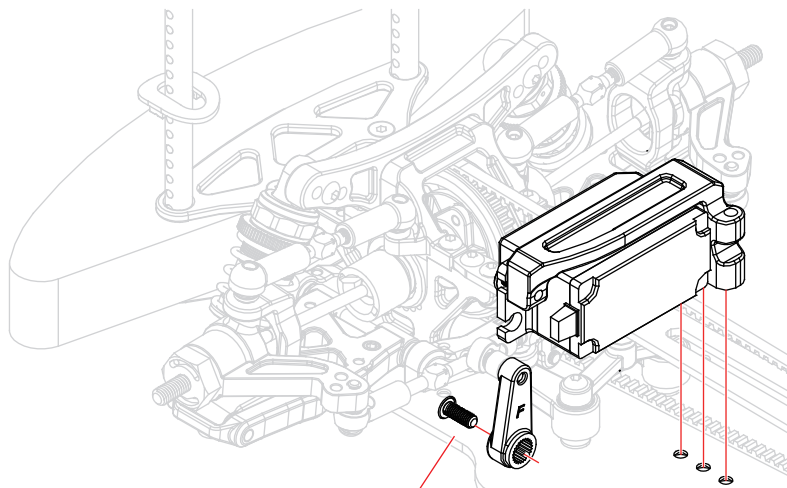

BS308/T01114  
M3x8 Screw  
M3x8 Schraube

FS308/T01119  
M3x8 Screw  
M3x8 Schraube

BS308/T01114 M3x8 Screw  
M3x8 Schraube

.....1

FS308/T01119 M3x8 Screw  
M3x8 Schraube

.....3

X Must be purchased separately  
Muss separat gekauft werden

**45** Motor Bag-H

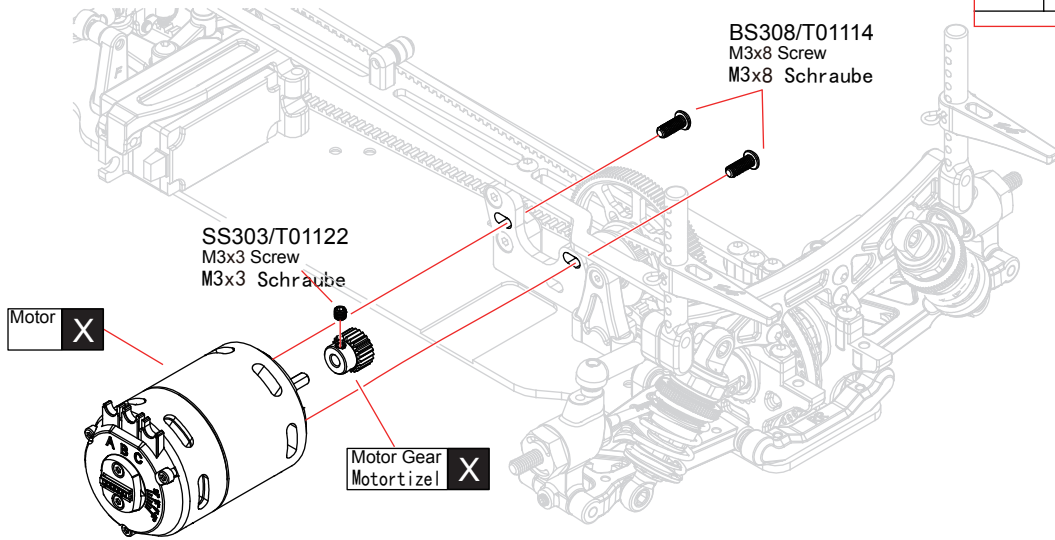
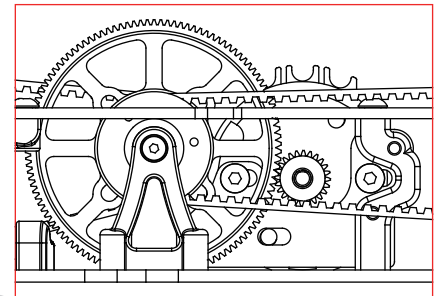

SS303/T01122 M3x3 Screw M3x3 Schraube	.....1
BS308/T01114 M3x8 Screw M3x8 Schraube	.....2

**46** ESC/Receiver ESC/RX Bag-H

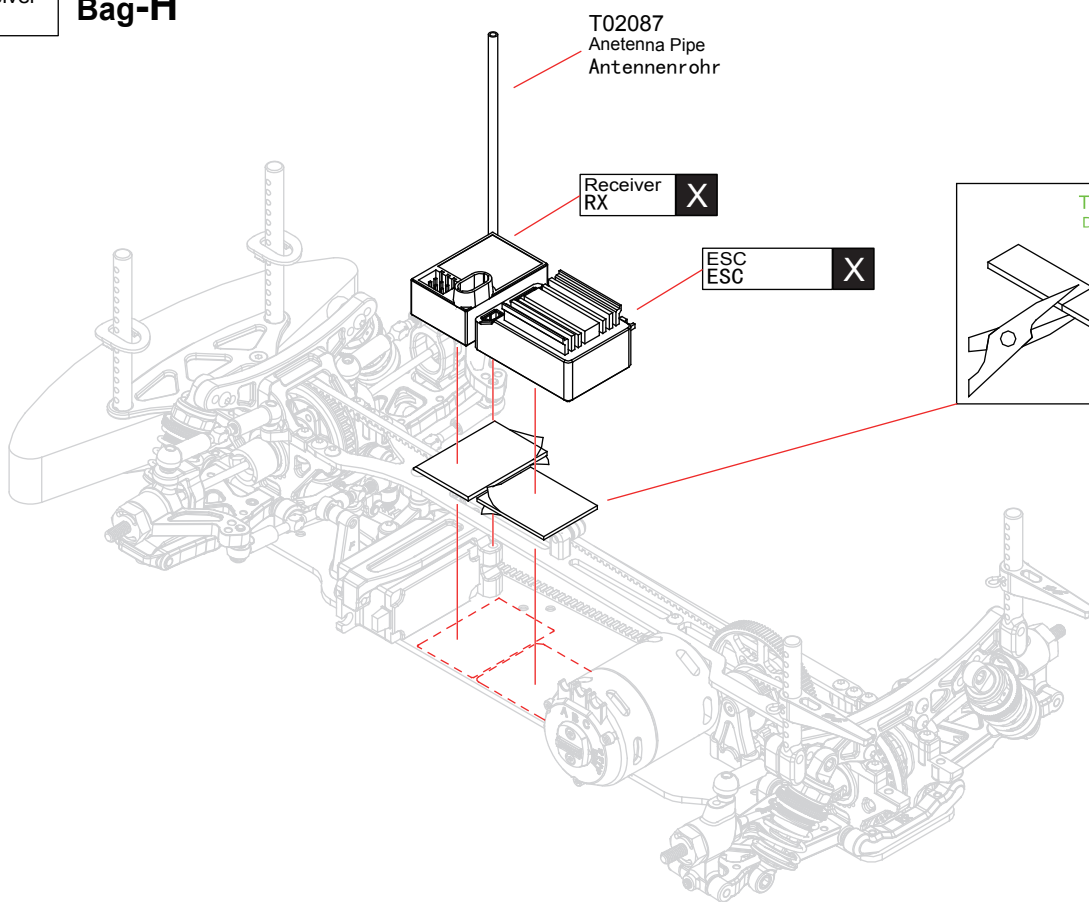

X Must be purchased separately  
Muss seperat gekauft werden

**47** Frame  
Rahmen **Bag-H**

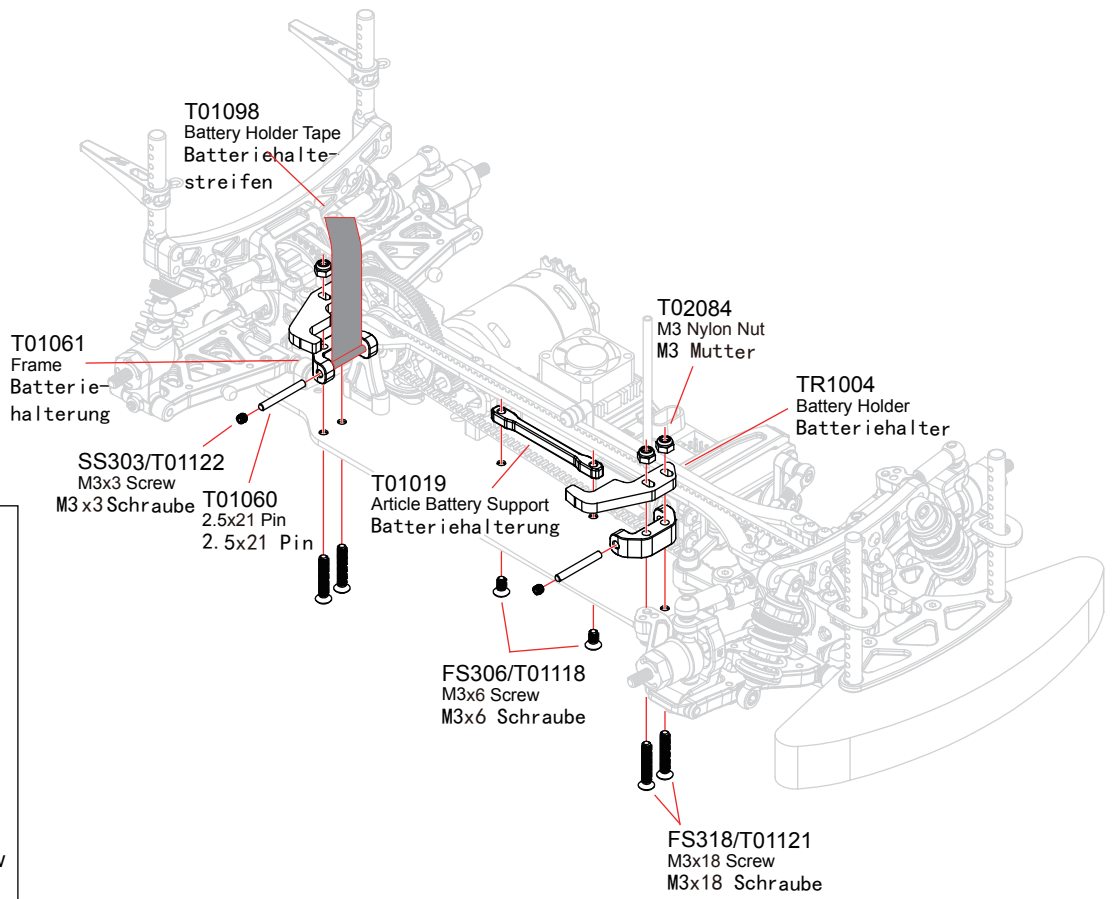

SS303/T01122 M3x3 Screw M3x3 Schraube	2
T01060 2.5x21 Pin 2.5x21 Pin	2
T02084 M3 Nylon Nut M3 Mutter	4
T01118 M3x6 Screw M3x6 Schraube	2
FS318/T01121 M3x18 Screw M3x18 Schraube	4



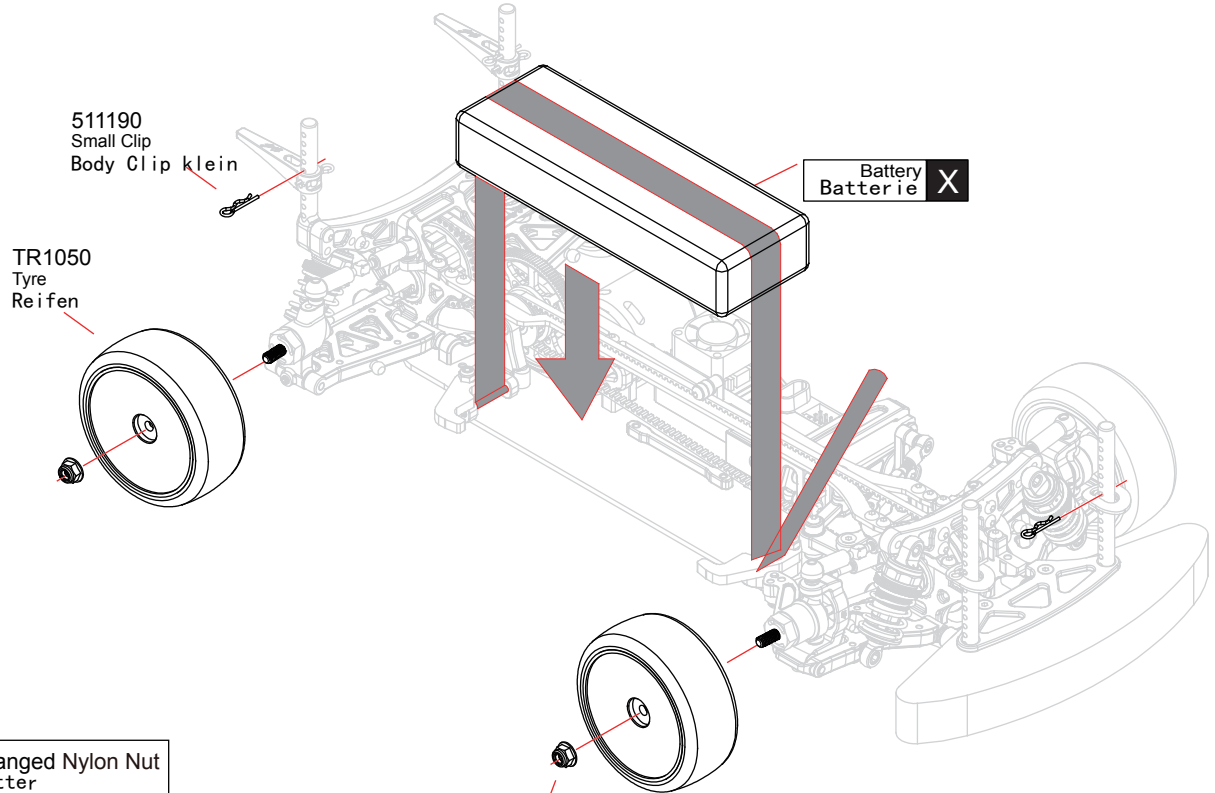





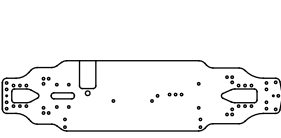
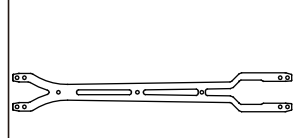

**48** Battery/Tyre  
Batterie/Reifen **Bag-H**

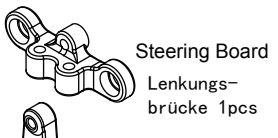
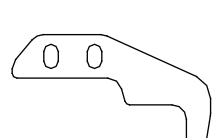
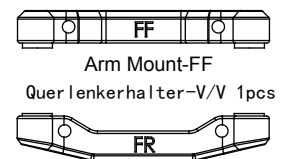
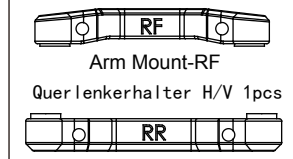
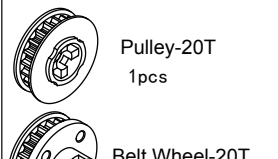
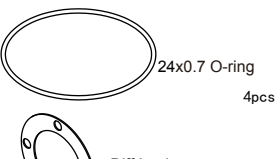
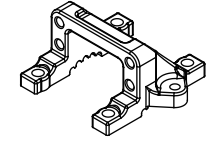

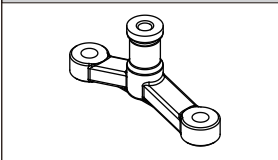
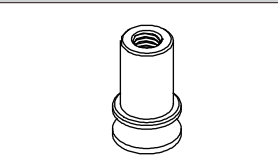
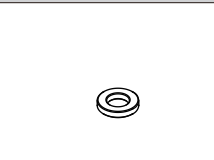
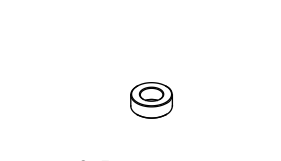
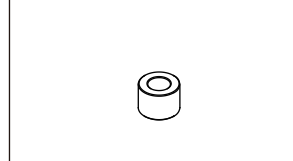
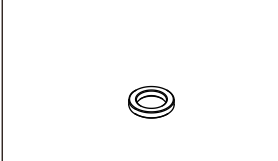
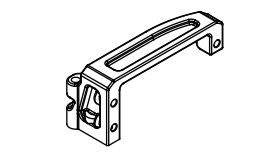
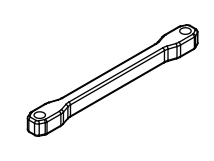
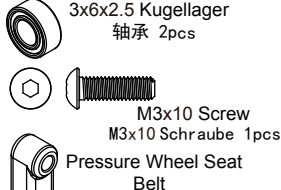
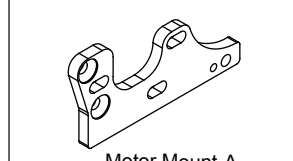



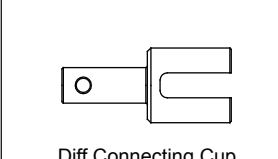

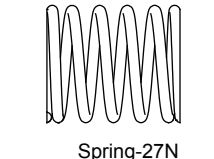
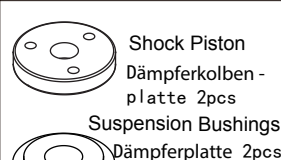
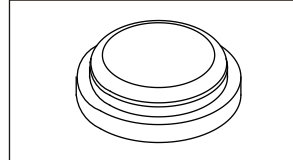
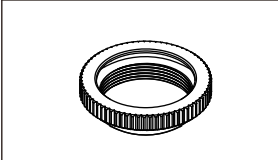
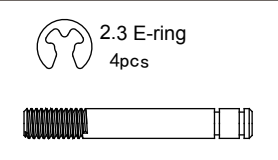
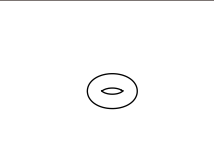



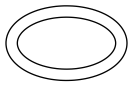

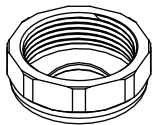
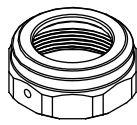
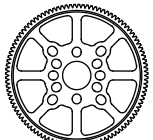
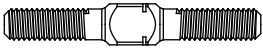
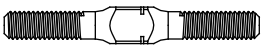
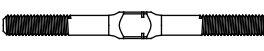

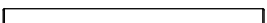
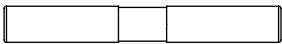

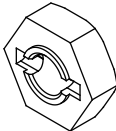

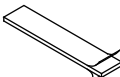
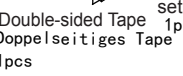
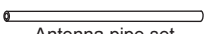
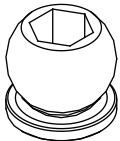

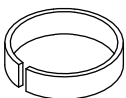
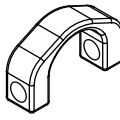

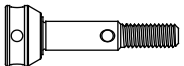

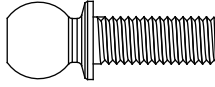
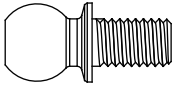

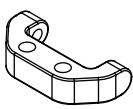
T02084 M4 Flanged Nylon Nut M4 Mutter	4
511190 Small Clip Body Clip klein	4



# Parts list for TR10 1/10 Touring Car - 1 TR10 Ersatzteile



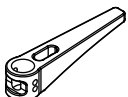
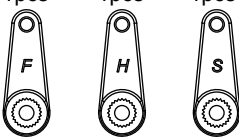







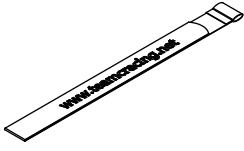

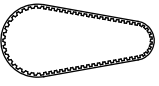







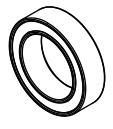

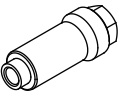

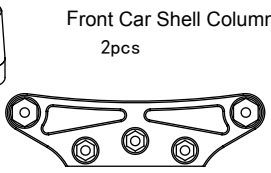
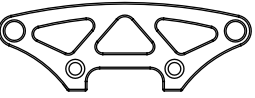
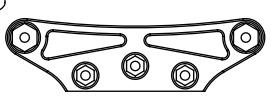
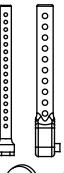

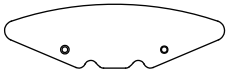
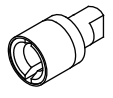



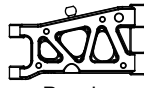
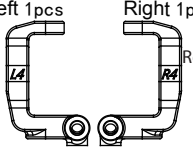
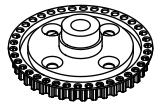



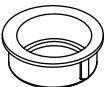

<p><b>TR1000</b></p>  <p>1pcs Carbon Style Chassis</p>	<p><b>TR1001</b></p>  <p>Carbon Style Top Deck Carbon Style Chassisplatte oben 1pcs</p>	<p><b>TR1002</b></p>  <p>Front Shock Tower Dämpferbrücke V 1pcs Rear Shock Tower Dämpferbrücke H 1pcs</p>	<p><b>TR1003</b></p>  <p>Steering Board Lenkungsbrücke 1pcs Servo Saver 2pcs</p>	<p><b>TR1004</b></p>  <p>Battery Holder Batteriehalter 2pcs</p>
<p><b>TR1005</b></p>  <p>Arm Mount-FF Querlenkerhalter-V/V 1pcs Arm Mount-FR Querlenkerhalter V/H 1pcs</p>	<p><b>TR1006</b></p>  <p>Arm Mount-RF Querlenkerhalter H/V 1pcs Arm Mount-RR Querlenkerhalter H/H 1pcs</p>	<p><b>TR1007</b></p>  <p>Pulley-20T 1pcs Belt Wheel-20T Riemenrad-20T 1pcs</p>	<p><b>T01097</b></p>  <p>24x0.7 O-ring 4pcs Diff Leakproof Spacer Diff Dichtung 1pcs</p>	<p><b>TR1008</b></p>  <p>Side Panel On The Cover Achshalterung oben 2pcs</p>
<p><b>T01094</b></p>  <p>4.9mm Ball End-Short 4.9mm Kugelpfanne kurz 10pcs 4.9mm Ball End-Long 4.9mm Kugelpfanne lang 4pcs 4.9mm Kugelpfanne 8pcs</p>	<p><b>T01012</b></p>  <p>Steering bridge rear Lenkungsbrücke hinten 1pcs</p>	<p><b>T01013</b></p>  <p>Buffer Bolumn Lenkungsaufnahme 2pcs</p>	<p><b>W3551/T01014</b></p>  <p>3x5.5x1 Washer Beilagscheibe 6pcs</p>	
<p><b>W3552/T01015</b></p>  <p>3x5.5x2 Washer Beilagscheibe 6pcs</p>	<p><b>W3554/T01016</b></p>  <p>3x5.5x4 Washer Beilagscheibe 6pcs</p>	<p><b>W461</b></p>  <p>4x6x1 Washer Beilagscheibe 2pcs</p>	<p><b>TR1009</b></p>  <p>Servo Plate Servohalterung 1pcs</p>	<p><b>T01019</b></p>  <p>Article Battery Support Batteriehalterung 1pcs</p>
<p><b>TR1010</b></p>  <p>3x6x2.5 Kugellager 轴承 2pcs M3x10 Screw M3x10 Schraube 1pcs Pressure Wheel Seat Belt Riemendrucklager 1pcs</p>	<p><b>TR1011</b></p>  <p>Motor Mount-A Motorhalter-A 1pcs</p>	<p><b>TR1012</b></p>  <p>Motor Mount-B Motorhalter-B 1pcs Center Diff Mount-A Mittel Diff Halter-A 1pcs Center Diff Mount-B Mittel Diff Halter-B 1pcs</p>	<p><b>TR1028</b></p>  <p>Axis Getriebeachse 1pcs</p>	
<p><b>511190</b></p>  <p>Small Clip Body Clip klein 10pcs</p>	<p><b>T01093</b></p>  <p>2.3 E-ring 10pcs</p>	<p><b>TR1013</b></p>  <p>Diff Connecting Cup Differentialmitnehmer 2pcs</p>	<p><b>TR1014</b></p>  <p>Shock Dämpfer 2pcs</p>	<p><b>TR1029</b></p>  <p>Spring-27N Dämpferfeder-27N 2pcs</p>
<p><b>TR1015</b></p>  <p>Shock Piston Dämpferkolbenplatte 2pcs Suspension Bushings Dämpferplatte 2pcs</p>	<p><b>T01040</b></p>  <p>Diaphragm Diaphragma 4pcs</p>	<p><b>TR1016</b></p>  <p>Spring Adjuster Rändelschraube 2pcs</p>	<p><b>TR1017</b></p>  <p>2.3 E-ring 4pcs Shock Absorber Shaft Dämpferkolbenstange 2pcs</p>	<p><b>T01035</b></p>  <p>2.8x1.9 O-ring 8pcs</p>

# Parts list for TR10 1/10 Touring Car - 2 TR10 Ersatzteile



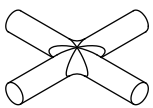







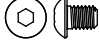

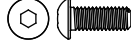
<p><b>T01036</b></p>  <p>13x1.5 O-ring 4pcs</p>	<p><b>TR1018</b></p>  <p>Shock Absorber Body Dämpferzylinder 2pcs</p>	<p><b>TR1019</b></p>  <p>Shock Below Cover Dämpferverschluss unten 2pcs</p>	<p><b>TR1020</b></p>  <p>Shock Upper Cover Dämpferverschluss oben 2pcs</p>	<p><b>T01092</b></p>  <p>Mid Gear-118T Hauptzahnrad 118T 1pcs</p>
<p><b>TR1021</b></p>  <p>2pcs 3x25 Turnbuckle 3x25 Gewindestange</p>	<p><b>TR1022</b></p>  <p>2pcs 3x28 Turnbuckle 3x28 Gewindestange</p>	<p><b>TR1023</b></p>  <p>2pcs 3x40 Turnbuckle 3x40 Gewindestange</p>	<p><b>TR1035</b></p>  <p>Rear Arm Pin-44mm Querlenkerwelle hinten 44mm 2pcs</p>	<p><b>TR1036</b></p>  <p>Front Arm Pin-41mm Querlenkerwelle vorne 41mm 2pcs</p>
<p><b>TR1037</b></p>  <p>25mm Arm PIN 25mm Querlenkerwelle 2pcs</p>	<p><b>TR1038</b></p>  <p>23mm Arm PIN 23mm Querlenkerwelle 2pcs</p>	<p><b>TR1027</b></p>  <p>Hex Mount Radmitnehmer 4pcs</p>	<p><b>T01049</b></p>  <p>5x15x0.3 Washer Beilagscheibe 2pcs</p>  <p>3.5x10x0.3 Washer Beilagscheibe 4pcs</p>	<p><b>T02087</b></p>  <p>Antenna pipe set cover 1pcs</p>  <p>Double-sided Tape Doppelseitiges Tape 1pcs</p>  <p>Antenna pipe set Antennenrohr 1pcs</p>
<p><b>TR1039</b></p>  <p>Shock Ball Kugelkopf für Dämpfer 4pcs</p>	<p><b>TR1040</b></p>  <p>4.9x5.5 Ball Stud Kugelkopf 4pcs</p>	<p><b>TR1041</b></p>  <p>Spring Buckle Pressfeder 1pcs</p>	<p><b>T01053</b></p>  <p>CVD Support 4pcs</p>	<p><b>TR1030</b></p>  <p>43mm Drive Shaft CVD Welle 2pcs</p>
<p><b>TR1031</b></p>  <p>44mm Drive Shaft CVD Welle 2pcs</p>	<p><b>TR1032</b></p>  <p>CVD Connecting Cup CVD Aufnahme 2pcs</p>	<p><b>TR1042</b></p>  <p>2x9.8 pin 4pcs</p>  <p>CVD Shaft 4pcs</p>	<p><b>TR1043</b></p>  <p>Ball Stud-Long Kugelkopf lang 6pcs</p>	<p><b>TR1044</b></p>  <p>Ball Stud-Short Kugelkopf kurz 4pcs</p>
<p><b>T01060</b></p>  <p>2.5x21 Pin 2pcs</p>	<p><b>T01061</b></p>  <p>Frame Batteriehalterung 2pcs</p>	<p><b>T01062</b></p>  <p>3x4x4.2 Steering Arm Sleeves 3x4x4.2 Lenkungs-lagerhülsen 2pcs</p>  <p>3x4x5.8 Steering Arm Sleeves 3x4x5.8 Lenkungs-lagerhülsen 2pcs</p>	<p><b>TR1024</b></p>  <p>Side Panel-L Achshalterung L 1pcs</p>  <p>Side Panel-R Achshalterung R 1pcs</p>	<p><b>P212/T01127</b></p>  <p>2x11.8 Pin 6pcs</p>
<p><b>T01126</b></p>  <p>5x1.9 O-ring 4pcs</p>	<p><b>T01124</b></p>  <p>8x2 Shock Absorber Sponge 8x2 Dämpferschaumstoff</p>	<p><b>T01125</b></p>  <p>Cover Plastic Brace Karosserieauflage 2pcs</p>	<p><b>T04006</b></p>  <p>1pcs 1pcs 1pcs Steering Servo Horn Servo Horn 1pcs</p>	<p><b>W3708/T02081</b></p>  <p>3x7x 0.8 Washer Beilagscheibe 10pcs</p>



# Parts list for TR10 1/10 Touring Car - 3 TR10 Ersatzteile

<p><b>T01098</b></p>  <p>Battery Holder Tape Batteriehaltestreifen 1pcs</p>	<p><b>TR1033</b></p>  <p>Belt Zahnriemen groß 1pcs</p>	<p><b>TR1034</b></p>  <p>Small Belt Zahnriemen klein 1pcs</p>	<p><b>T02084</b></p>  <p>M4 Flanged Nylon Nut Mutter 6pcs</p>  <p>M3 Nylon Nut Mutter 6pcs</p>	<p><b>P210/T04032</b></p>  <p>2x9.8 Pin 6pcs</p>
<p><b>B040803/T01074</b></p>  <p>4x8x3 Ball Bearing Kugellager 6pcs</p>	<p><b>B0306025/T02080</b></p>  <p>3x6x2.5 Ball Bearing Kugellager 4pcs</p>	<p><b>B0508025/T01075</b></p>  <p>5x8x2.5 Ball Bearing Kugellager 6pcs</p>	<p><b>B051004/T02100</b></p>  <p>5x10x4 Ball Bearing Kugellager 6pcs</p>	<p><b>B101504/T02099</b></p>  <p>10x15x4 Ball Bearing Kugellager 6pcs</p>
<p><b>B0306025/T01076</b></p>  <p>3x6x2.5 Ball Bearing Kugellager 6pcs</p>	<p><b>TR1025</b></p>  <p>Anti-collision Plate Plastic Column Rammschutzverstrebung 2pcs</p>	<p><b>T01078 Rammschutz und Karosseriebefestigungs Set</b></p>  <p>Antenna Socket 1pcs</p>  <p>Front Car Shell Column 2pcs</p>  <p>Anti-collision Plate Board 1pcs</p>  <p>Anti-collision Plate Under 1pcs</p>  <p>Front Car Shell Column 2pcs</p>  <p>Car Shell Support Seat 4pcs</p>		
<p><b>T01079</b></p>  <p>Anti-collision Sponge Stoßfänger Schaumstoff 1pcs</p>	<p><b>TR1045</b></p>  <p>Diff Connecting Cup Diff Mitnehmer 2pcs</p>	<p><b>T01081</b></p>  <p>Left 1pcs Links</p>  <p>Right 1pcs Rechts</p> <p>Front Lower Arm Querlenker vorne</p>	<p><b>T01082</b></p>  <p>Left 1pcs Links</p>  <p>Right 1pcs Rechts</p> <p>Rear Lower Arm Querlenker hinten</p>	<p><b>T01083</b></p>  <p>Left 1pcs Right 1pcs Links Rechts</p> <p>C-type Holder Achsschenkelhalter</p>
<p><b>T01084</b></p>  <p>Differential Belt Tooth-38T Diff Zahnrad-38T 1pcs</p>	<p><b>TR1026</b></p>  <p>Differential Shell Diff Zahnrad 1pcs</p>	<p><b>T01084</b></p>  <p>Plastic Straight Shaft Starrachse 1pcs</p>	<p><b>TR1026</b></p>  <p>Pulley-38T 1pcs</p>	<p><b>T01086</b></p>  <p>Straight Shaft Gear Ring Starrachse Ring 1pcs</p>  <p>Belt Adjustment Ring Riemen Einstellring 4pcs</p>
<p><b>T01087</b></p>  <p>Steering Arm Lenkhebel l/r 2pcs</p>	<p><b>T01088</b></p>  <p>Rear Hub Achsschenkel hinten 2pcs</p>	<p><b>T01089</b></p>  <p>Shock Absorber Cover Dämpferauge 2pcs</p>	<p><b>T01089</b></p>  <p>Below Spring Mount End Federteller 2pcs</p>	<p><b>SS304/T01123</b></p>  <p>Ball End Kugelpfanne 2pcs</p>  <p>M3x4 Screw Schraube 10pcs</p>
<p><b>T01091</b></p>  <p>Diff Gear-10T Diff Zahnrad-10T 4pcs</p>  <p>Diff Gear-18T Diff Zahnrad-18T 2pcs</p>  <p>With Poor Spider Zahnradkreuz 1pcs</p>	<p><b>SS308/T01095</b></p>  <p>M3x8 Screw Schraube 10pcs</p>	<p><b>SS408/T01096</b></p>  <p>M4x8 Screw Schraube 10pcs</p>	<p><b>SS303/T01122</b></p>  <p>M3x3 Screw Schraube 10pcs</p>	<p><b>SS303/T01122</b></p>  <p>M3x3 Screw Schraube 10pcs</p>

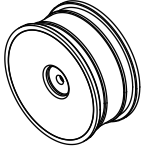
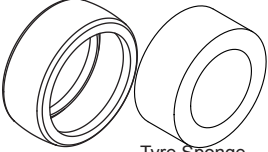
# Parts list for TR10 1/10 Touring Car - 4 TR10 Ersatzteile

<p><b>FS318/T01121</b></p>  <p>M3x18 Screw Schraube 10pcs</p>	<p><b>BS304/T01112</b></p>  <p>M3x4 Screw Schraube 10pcs</p>	<p><b>BS306/T01113</b></p>  <p>M3x6 Screw Schraube 10pcs</p>	<p><b>BS308/T01114</b></p>  <p>M3x8 Screw Schraube 10pcs</p>	<p><b>BS310/T01115</b></p>  <p>M3x10 Screw Schraube 10pcs</p>
<p><b>BS312/T01116</b></p>  <p>M3x12 Screw Schraube 10pcs</p>	<p><b>FS2508/T01117</b></p>  <p>M2.5x8 Screw Schraube 10pcs</p>	<p><b>FS306/T01118</b></p>  <p>M3x6 Screw Schraube 10pcs</p>	<p><b>FS308/T01119</b></p>  <p>M3x8 Screw Schraube 10pcs</p>	<p><b>FS310/T01120</b></p>  <p>M3x10 Screw Schraube 10pcs</p>
<p><b>TR1046</b></p>  <p>Fiberglass Chassis 1pcs</p>	<p><b>TR1047</b></p>  <p>Fiberglass Top Deck 1pcs</p>	<p><b>TR1048</b></p>  <p>Wheel Felge 2pcs</p>	<p><b>TR1049</b></p>  <p>Tyre Reifen 2pcs</p> <p>Tyre Sponge Reifeneinlage 2pcs</p>	<p><b>TR1050</b></p>  <p>Tyre Komplett Reifen 2pcs</p>
		<p>、</p> <p>、</p>		

# TR10

RACE			
TRACK			
NAME			
CITY/COUNTRY			
CONTACT			
DATE	AIR TEMP	TRACK TEMP	HUMIDITY
QUALIFYING POSITION		BEST LAP TIME/sex	
FINAL POSITION		RACE LENGTH/minutes	

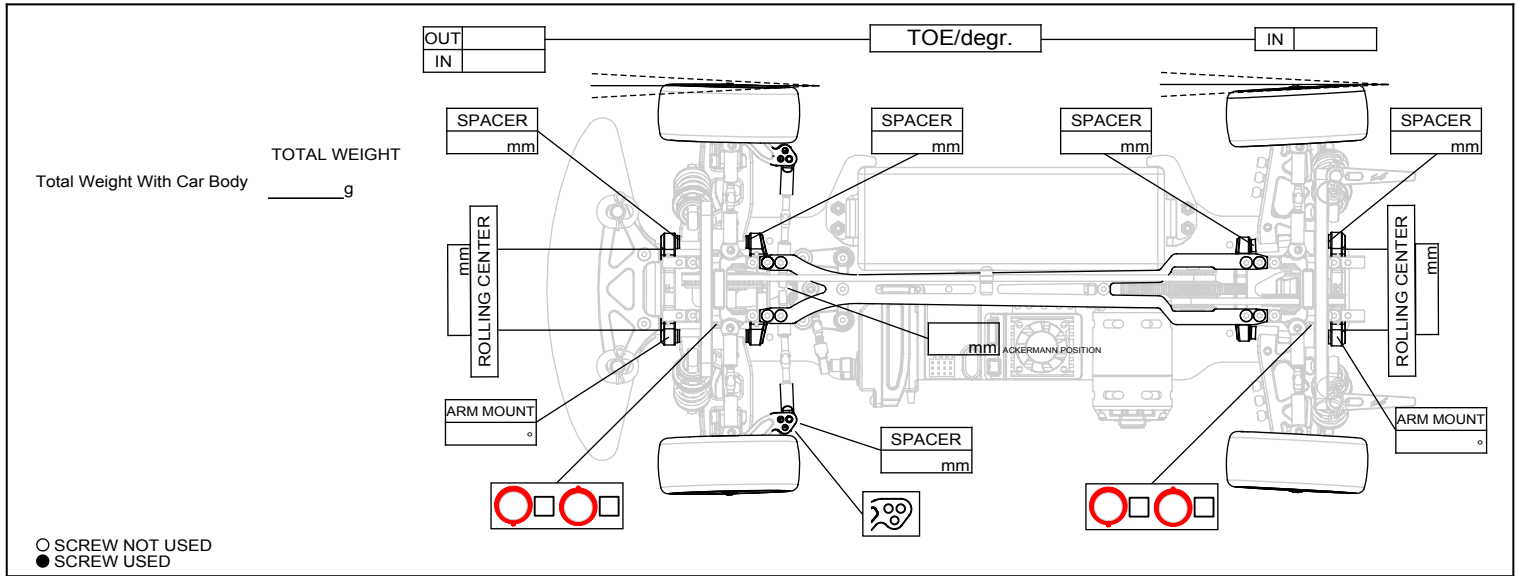
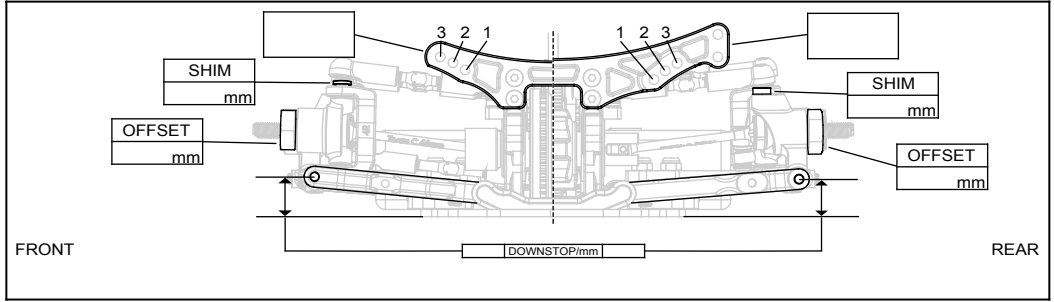
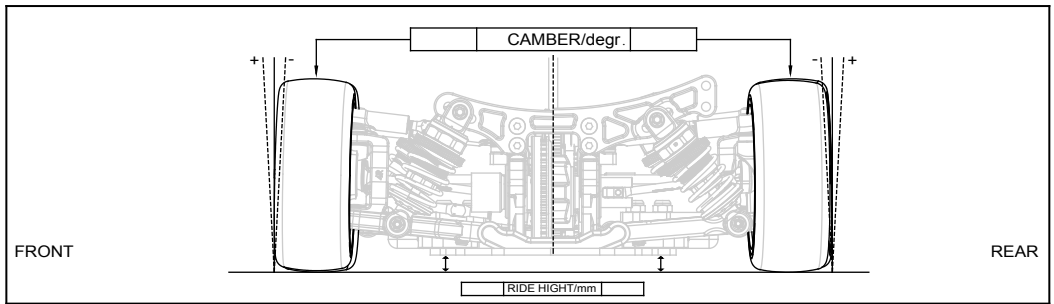

SHOCKS	
FRONT	REAR
SPRING	
OIL/W	
LENGTH/mm	
REBOUND/%	
<input type="checkbox"/> YES <input type="checkbox"/> NO	FOAM INSERTS <input type="checkbox"/> YES <input type="checkbox"/> NO
	HOLES IN PISTON

TRACK CONDITION	<input type="checkbox"/> CONCRETE <input type="checkbox"/> CARPET <input type="checkbox"/> ASPHALT
	<input type="checkbox"/> TECHNICAL <input type="checkbox"/> MIXED <input type="checkbox"/> FAST
TRACTION	<input type="checkbox"/> LOW <input type="checkbox"/> MEDIUM <input type="checkbox"/> HIGH
ESC	BATTERIES
BODY	WING
ARMATURE	TIMING
MOTOR	
FINAL GEAR RATIO	
PINION/T	SPUR GEAR/T
T	T
TRANSMISSION	
FRONT	REAR
<input type="checkbox"/>	<input type="checkbox"/>
GEAR DIFFERENTIAL	
<input type="checkbox"/> W	<input type="checkbox"/> W
ONE WAY DIFFERENTIAL <input type="checkbox"/>	SOLID AXLE <input type="checkbox"/>

TIRES	
DIAMETER	
INSERTS	
ADDITIVE	

ANTI-ROLL BAR	
FRONT	REAR
<input type="checkbox"/> 1.2	<input type="checkbox"/> 1.1
<input type="checkbox"/> 1.3	<input type="checkbox"/> 1.2
<input type="checkbox"/> 1.4	<input type="checkbox"/> 1.3
<input type="checkbox"/> 1.5	<input type="checkbox"/> 1.4

TREATED AREA			
FRONT LEFT	FRONT RIGHT	REAR LEFT	REAR RIGHT

COMMENTS

*Team*  
*Team*  
[www.teamcracing.net](http://www.teamcracing.net)